



# BISPLATE<sup>®</sup>

technical guide





For more information regarding BISPLATE® refer to the technical information pdf documents provided on the Bisalloy Steels® website at [www.bisalloy.com.au](http://www.bisalloy.com.au)



# **BISPLATE**<sup>®</sup>

technical guide



## CONTENTS

Introduction	3
How to Contact Us	4
Process Route	5
Range of Grades	6
BISPLATE® Size Range	30
Manufacturing Tolerances	31
Cutting BISPLATE®	35
Welding BISPLATE®	45
Bending, Rolling, Shearing and Punching BISPLATE®	64
Drilling, Countersinking & Tapping BISPLATE®	69
Turning and Milling BISPLATE®	76
BISPLATE® Identification Marking and Colour Coding	81
Testing and Certification	83
Hardness Testing BISPLATE®	85

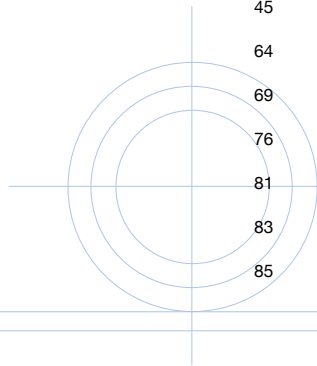

## INTRODUCTION

Bisalloy Steels Pty Ltd, located at Unanderra, NSW is Australia's only manufacturer of high strength, wear resistant and armour grade steel plate produced by the continuous roller quenching and tempering process.

Quenching and tempering, defined as a combination of heating and cooling of a metal or alloy, changes the microstructure of the steel and improves the strength, hardness and toughness of the materials being treated.

Utilising the most advanced heat treatment technology, furnace temperatures and quenching rates are scientifically controlled using PLC's to obtain the optimum quality grades of steel with low alloy content. The resulting products of low alloy quenched and tempered steel offer designers the strength to weight advantages and wear resistant properties not available in conventional steels.

High strength steel has a strength to weight ratio of approximately three times that of mild steel. Principal applications are in mining equipment, transport, telescopic cranes, materials handling equipment, high rise construction and forestry. High hardness grades offer improved wear life making it ideal for applications such as liners for chutes, buckets, dump trucks etc. BISPLATE® armour grades are suitable for armoured personnel carriers and ballistic protection of military and civilian fixed plant and transport equipment.

BISPLATE® grades can be readily cut, welded, formed and drilled using similar techniques to mild steel.

Bisalloy Steels® operates an approved mechanical testing laboratory registered and monitored by the Australian National Association of Testing Authorities (NATA). The company's quality control and management system is assessed by Lloyds and accredited to ISO9001.

The capacity, quality and versatility of our heat treatment line enables us to compete in both domestic and international markets; including North and South America, Asia, New Zealand and Africa.

## HOW TO CONTACT US

### **BISALLOY STEELS PTY LTD**

18 Resolution Drive Unanderra

PO Box 1246 Unanderra NSW 2526 Australia

Tel Switch +61 2 4272 0444

Fax +61 2 4272 0456

Web Site [www.bisalloy.com.au](http://www.bisalloy.com.au)

### **TECHNICAL MANAGER**

Russell Barnett

Tel +61 2 4272 0470

Mob 0418 271 948

[russell.barnett@bisalloy.com.au](mailto:russell.barnett@bisalloy.com.au)

### **NATIONAL SALES MANAGER**

Terry McDermott

Tel +61 2 4272 0432

Mob 0406 398 421

[terry.mcdermott@bisalloy.com.au](mailto:terry.mcdermott@bisalloy.com.au)

### **SALES & MARKETING MANAGER**

Michael Sampson

Tel +61 2 4272 0412

Mob 0418 603 852

[michael.sampson@bisalloy.com.au](mailto:michael.sampson@bisalloy.com.au)

### **EXPORT MANAGER**

Willy Pang

Tel +61 2 4272 0418

Mob +61 419 280 765

[willy.pang@bisalloy.com.au](mailto:willy.pang@bisalloy.com.au)

**FOR STATE BY STATE ENQUIRIES PLEASE CONTACT  
OUR MAIN OFFICE ON 02 4272 0444**



# PROCESS ROUTE

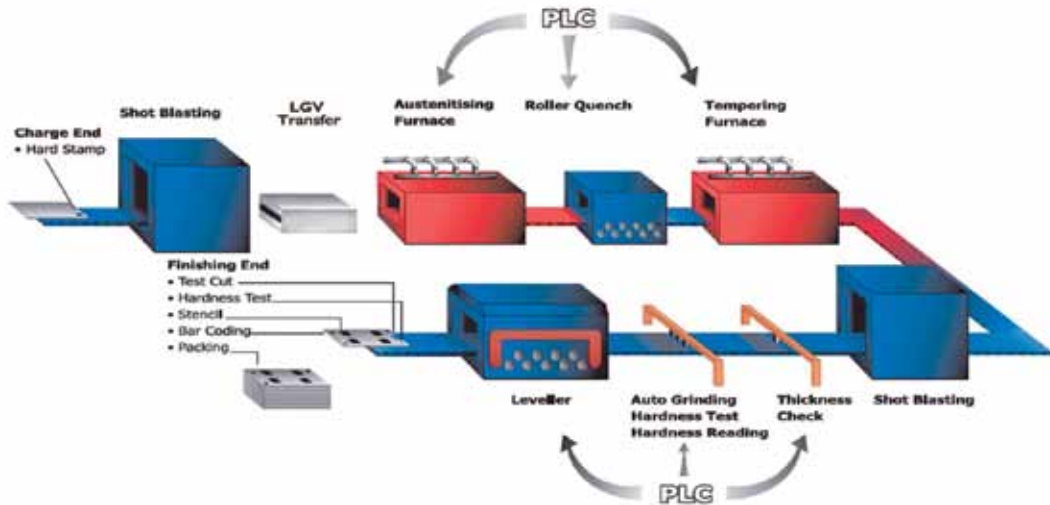

HOW TO CONTACT US

PROCESS ROUTE

## **RANGE OF GRADES**

### **INTRODUCTION**

Bisalloy Steel's® grades are world class, our structural grades complying with many of the world's quenched and tempered steel plate standards.

Each of the grades covered by this brochure has specific mechanical and chemical properties detailed. The process information detailed below is applicable to all BISPLATE® product manufactured by Bisalloy Steels®.

### **BISALLOY'S FEED PLATE**

The technology used in the manufacture of BISPLATE® is not only world class, but the demands of high strength and high hardness steels dictate the need for one of the most stringent process routes utilised in the manufacture of steel plate, anywhere in the world.

Hot metal desulphurisation ensures low levels of sulphur and other impurities in steelmaking. Vacuum degassing is carried out to reduce the Hydrogen content of the steel, whilst also decreasing the amount of undesirable Oxygen and Nitrogen in the steel. Control of impurities is additionally assisted through the use of hot metal injection and conditioning of the slag during the Basic Oxygen Steelmaking process.

Close control of chemical composition and final microstructure is maintained through the use of ladle refining with Calcium injection, Argon bubbling through the heat during steelmaking and alloying additions made under vacuum.

Following steelmaking, integrity of slab product is ensured by the use of electromagnetic stirring, continuous casting and controlled cooling of slabs prior to plate rolling.

Finally, plate rolling is carried out in a computer controlled four high rolling mill, in which each draft is modified during rolling for optimisation of final properties.

The net result is steel that provides improved toughness, structural integrity and fatigue resistance, providing consistent product performance in service.

## **BISALLOY'S HEAT TREATMENT**

Plate is heated in our natural gas fired furnace, prior to quenching in the Drever roller quench unit. Complete PLC control allows tight and consistent control of all furnace and quench operations, including water flow rates and pressure, furnace temperatures and residence times.

Pre and post-heat treatment shot blasting removes scale and presents an attractive plate. This results in improvements in product properties, welding and cutting, as well as simplification during fabrication.

The final operation at Bisalloy is plate levelling, through our plate leveller, for material up to 32mm thick. This has resulted in significant improvements in flatness of plate to market, much tighter than the Australian Standard and other International Standards.

Our quality assurance system ensures that full traceability exists from initial steelmaking right through the process to the final plate. Each plate is individually hard stamped with a unique identification, this links to the overall traceability.

All plates are tested for hardness, whilst all structural grades are tested in Bisalloy's NATA approved mechanical testing laboratory. Plates of all grades are certified. The entire process is carried out in compliance with ISO9001, certified by Lloyd's Register Quality Assurance (LRQA).

## **BISALLOY'S TECHNICAL DEVELOPMENT**

Each of the grades outlined in this brochure have been developed to optimise chemistry and mechanical properties in conjunction with Bisalloy's heat treatment process.

Our world class steel grades ensure that properties such as ductility, weldability and toughness are maximised, whilst complying with the requisite hardness and strength requirements.

Ongoing R&D at Bisalloy keeps our product range at the leading edge of available quenched and tempered steels. Already, we are developing steels to meet the emerging requirements for still stronger structural grades and these will be released to the market as demand dictates.

## BISPLATE® 60

BISPLATE® 60 is a low carbon, low alloy, high strength structural steel that exhibits excellent cold formability and low temperature fracture toughness.

### APPLICATIONS

The combination of BISPLATE® 60 mechanical properties and ease of fabrication offers economical advantages in many structural applications. Some examples of applications for this grade include:

- Storage tanks *(Water/Oil/Gas)*
- High-rise buildings *(Columns/Transfer beams)*
- Lifting equipment *(Mobile/Overhead cranes)*

### FABRICATION

BISPLATE® 60 can be welded successfully with minimal levels of preheat and has excellent low temperature fracture toughness.

BISPLATE® 60 has been designed such that a low hardness level is produced in the heat affected zone (HAZ). As a result, this steel has a low susceptibility to HAZ cracking.

For further details on fabrication please refer to Bisalloy's technical literature.

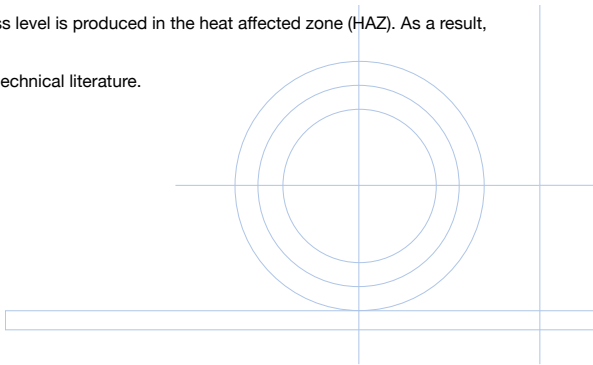

## BISPLATE® 60

### MECHANICAL PROPERTIES

PROPERTIES	SPECIFICATION	TYPICAL
0.2% Proof Stress	500 MPa (Min)	580 MPa
Tensile Strength	590 - 730 MPa	640 MPa
Elongation in 50mm G.L.	20% (Min)	30%
Charpy Impact (Longitudinal) -20°C (10mm x 10mm)	80J (Min)*	200J
Hardness		210HB

\*Dependant on plate thickness

### CHEMICAL COMPOSITION

THICKNESS (mm)		C	P	Mn	Si	S	Cr	Mo	B	CE(IIW)*	CET*
5 - <16	Maximum	0.18	0.025	1.5	0.25	0.008	0.25	0.25	0.002	0.40	0.29
≥16 - 80	Maximum	0.20	0.025	1.5	0.25	0.008	0.30	0.25	0.002	0.50	0.35
>80 - 100	Maximum	0.18	0.025	1.5	0.25	0.008	1.20	0.25	0.002	0.58	0.34

\*Typical Average

## BISPLATE® 70

BISPLATE® 70 is a low carbon, low alloy, high strength structural steel. This grade can be welded with minimal preheat and has excellent low temperature fracture toughness suitable for structural applications.

### APPLICATIONS

The combination of BISPLATE® 70 mechanical properties and ease of fabrication offers economical advantages in many structural applications. Some examples of applications for this grade include:

- Transport equipment (*Trays/Low loaders/Outriggers*)
- Storage tanks (*Water/Oil/Gas*)
- High-rise buildings (*Columns/Transfer beams*)
- Lifting equipment (*Mobile/Overhead cranes*)
- Mining equipment (*Dump truck trays/Structural applications*)
- Longwall mining supports

### FABRICATION

BISPLATE® 70 exhibits excellent cold formability and low temperature fracture toughness.

BISPLATE® 70 has been designed such that a low hardness level is produced in the heat affected zone (HAZ). As a result, this steel has a low susceptibility to HAZ cracking.

For further details on fabrication please refer to Bisalloy's technical literature.

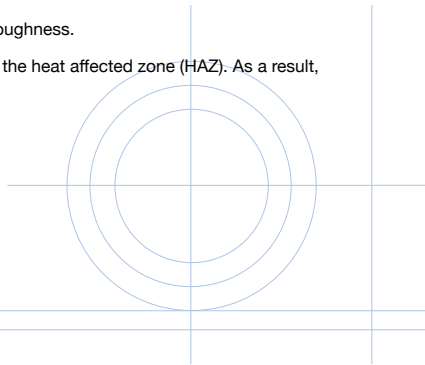

## BISPLATE® 70

### MECHANICAL PROPERTIES

PROPERTIES	SPECIFICATION	TYPICAL
0.2% Proof Stress	600 MPa (Min)	670 MPa
Tensile Strength	690 - 830 MPa	760 MPa
Elongation in 50mm G.L.	20% (Min)	28%
Charpy Impact (Longitudinal) -20°C (10mm x 10mm)	75J (Min)*	180J
Hardness		230HB

\*Dependant on plate thickness

### CHEMICAL COMPOSITION

THICKNESS (mm)		C	P	Mn	Si	S	Cr	Mo	B	CE(IIW)*	CET*
5 - <16	Maximum	0.18	0.025	1.5	0.25	0.008	0.25	0.25	0.002	0.40	0.29
≥16 - 80	Maximum	0.20	0.025	1.5	0.25	0.008	0.30	0.25	0.002	0.50	0.35
>80 - 100	Maximum	0.18	0.025	1.5	0.25	0.008	1.20	0.25	0.002	0.58	0.34

\*Typical Average

## BISPLATE® 80

BISPLATE® 80 is a high strength, low alloy steel plate with a yield strength three times that of carbon steel and featuring low carbon, excellent notch toughness, good weldability and formability.

### APPLICATIONS

Utilising the high strength properties of BISPLATE® 80 allows reduction in section thickness without loss of structural integrity. The following lists some applications where the strength advantage has been realised:

- Transport equipment (*Low loaders*)
- High-rise buildings (*Columns*)
- Mining equipment (*Dump truck trays/Longwall roof supports*)
- Lifting equipment (*Mobile cranes/Container handling equipment*)
- Bridges
- Storage tanks
- Excavator buckets
- Induced draft fans

### FABRICATION

BISPLATE® 80 is a high strength steel manufactured with a controlled carbon equivalent for optimum weldability.

BISPLATE® 80 can be successfully welded to itself and a range of other steels, provided low hydrogen consumables are used and attention is paid to preheat, interpass temperature, heat input and the degree of joint restraint. Stress relieving can be achieved at 540°C – 570°C. Heating above this temperature should be avoided to minimise any adverse effects on mechanical properties. Cold forming can be successfully conducted, provided due account is taken of the increased strength of the steel.

For further details on fabrication please refer to Bisalloy's technical literature.

## BISPLATE® 80

### MECHANICAL PROPERTIES

PROPERTIES	SPECIFICATION	TYPICAL
0.2% Proof Stress	690 MPa (Min)*	750 MPa
Tensile Strength	790 - 930 MPa*	830 MPa
Elongation in 50mm G.L.	18% (Min)*	26%
Charpy Impact (Longitudinal) -20°C (10mm x 10mm)	40J (Min)*	160J
Hardness		255HB

\*Dependant on Plate Thickness

### CHEMICAL COMPOSITION

THICKNESS (mm)		C	P	Mn	Si	S	Cr	Mo	B	CE(IIW)*	CET*
5 - <16	Maximum	0.18	0.025	1.5	0.25	0.008	0.25	0.25	0.002	0.40	0.29
≥16 - 80	Maximum	0.20	0.025	1.5	0.25	0.008	0.30	0.25	0.002	0.50	0.35
>80 - 100	Maximum	0.18	0.025	1.5	0.25	0.008	1.20	0.25	0.002	0.58	0.34

\*Typical Average

## BISPLATE® 80PV

BISPLATE® 80PV is a high strength steel alternative for designers of unfired pressure vessels that meets the requirements of AS1210 and achieves a light weight structure.

### APPLICATIONS

BISPLATE® 80PV has been approved by statutory authorities and complies with the requirements of AS1210 for pressure applications and is supplied ultrasonically tested to AS1710-Level 1. Its high strength offers substantial weight reductions in the following areas:

- Transportable road tankers
- Storage tanks *(Spherical and cylindrical)*
- Railroad tankers *(LPG/Liquid ammonia)*
- Refinery and petrochemical equipment *(Tube plates/Channel covers)*

### FABRICATION

BISPLATE® 80PV is a high strength, low alloy pressure vessel steel with a controlled carbon equivalent for optimum weldability.

BISPLATE® 80PV can be successfully welded to itself and a range of other steels, provided low hydrogen consumables are used and attention is paid to preheat, interpass temperature, heat input and the degree of joint restraint. Stress relieving can be achieved at 540°C – 570°C. Heating above this temperature should be avoided to minimise any adverse effects on mechanical properties. Cold forming can be conducted successfully, provided due account is taken of the increased strength of the steel.

## BISPLATE® 80PV

### MECHANICAL PROPERTIES

PROPERTIES	SPECIFICATION	TYPICAL
0.2% Proof Stress	690 MPa (Min)*	750 MPa
Tensile Strength	790 - 930 MPa*	830 MPa
Elongation in 50mm G.L.	18% (Min)*	26%
Lateral Expansion	0.38mm (Min)	0.70mm
Charpy Impact	-	55J
Hardness	-	255HB

\*Dependant on plate thickness.

### CHEMICAL COMPOSITION

THICKNESS (mm)		C	P	Mn	Si	S	Cr	Mo	B	CE(IIW)*	CET*
≥6 - 80	Maximum	0.20	0.025	1.5	0.25	0.008	0.30	0.25	0.002	0.50	0.35
>80 - 100	Maximum	0.18	0.025	1.5	0.25	0.008	1.20	0.25	0.002	0.58	0.34

\*Low heat input butt welding required to ensure transverse weld tensile properties are achieved. Alternate chemistry may be specified when necessary.

\*Typical Average

## BISPLATE® 320

BISPLATE® 320 is a through hardened, abrasion resistant steel plate, offering long life expectancy in high impact abrasion applications.

### APPLICATIONS

BISPLATE® 320 offers the optimum combination of hardness, impact and formability for wear applications that require extensive forming/drilling or fabrication, in impact abrasive applications such as:

- Deflector plates
- Chutes
- Storage bins
- Dump truck liners
- Earthmoving buckets

### FABRICATION

BISPLATE® 320 is a high hardness, abrasion resistant steel with a controlled carbon equivalent for optimum weldability. With appropriate attention to heat input, preheat and consumable selection, BISPLATE® 320 can be readily welded to itself and other steels, using conventional processes.

Cold forming of BISPLATE® 320 plates is possible in all thicknesses, provided the high strength of this steel is taken into account. Adequate allowance must be made for increased springback relative to mild steel. Heating above 400°C should be avoided, otherwise the mechanical properties might be affected.

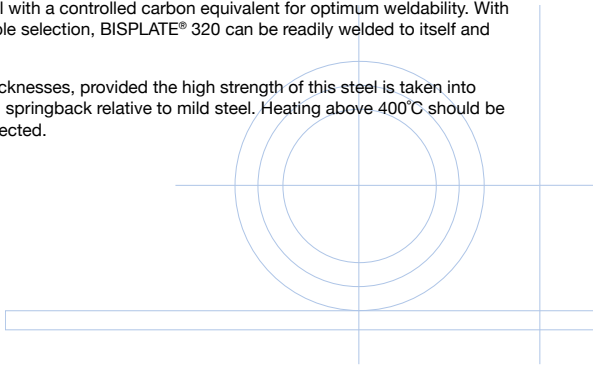

## BISPLATE® 320

### MECHANICAL PROPERTIES

PROPERTIES	SPECIFICATION	TYPICAL
0.2% Proof Stress	-	970 MPa
Tensile Strength	-	1070 MPa
Elongation in 50mm G.L.	-	18%
Charpy Impact (Longitudinal) +20°C (10mm x10mm)	-	60J
Hardness	320 - 360HB	340HB

### CHEMICAL COMPOSITION

THICKNESS (mm)		C	P	Mn	Si	S	Cr	Mo	B	CE(IIW)*	CET*
5 - <16	Maximum	0.18	0.025	1.5	0.25	0.008	0.25	0.25	0.002	0.40	0.29
≥16 - 80	Maximum	0.20	0.025	1.5	0.25	0.008	0.30	0.25	0.002	0.50	0.35
>80 - 100	Maximum	0.18	0.025	1.5	0.25	0.008	1.20	0.25	0.002	0.58	0.34

\*Typical Average

## BISPLATE® 400

BISPLATE® 400 is a through hardened, abrasion resistant steel plate, offering long life expectancy in high impact abrasion applications.

### APPLICATIONS

BISPLATE® 400 offers excellent wear and abrasion resistance and impact toughness in applications that include:

- Dump truck wear liners
- Cyclones
- Screw conveyors
- Deflector plates
- Chutes
- Ground engaging tools
- Storage bins
- Cutting edges
- Earthmoving buckets

### FABRICATION

BISPLATE® 400 is a high hardness, abrasion resistant steel offering very good impact toughness properties. BISPLATE® 400 provides an optimum combination of abrasion resistance, toughness and weldability. Due to its low alloy content, BISPLATE® 400 can be readily welded using conventional welding processes and low hydrogen consumables. Cold forming of BISPLATE® 400 is achievable on all thicknesses although an allowance for the higher strength should be taken into account. Bending machine capabilities should also be taken into consideration prior to any forming operation. Heating above 250°C should be avoided, otherwise mechanical properties might be affected.

## BISPLATE® 400

### MECHANICAL PROPERTIES

PROPERTIES	SPECIFICATION	TYPICAL
0.2% Proof Stress	-	1070 MPa
Tensile Strength	-	1320 MPa
Elongation in 50mm G.L.	-	14%
Charpy Impact (Longitudinal) +20°C (10mm x10mm)	-	55J
Hardness	370 - 430HB	400HB

### CHEMICAL COMPOSITION

THICKNESS (mm)		C	P	Mn	Si	S	Cr	Mo	B	CE(IIW)*	CET*
5 - <16	Maximum	0.18	0.025	1.5	0.25	0.008	0.25	0.25	0.002	0.40	0.29
≥16 - 80	Maximum	0.20	0.025	1.5	0.25	0.008	0.30	0.25	0.002	0.50	0.35
>80 - 100	Maximum	0.18	0.025	1.5	0.25	0.008	1.20	0.25	0.002	0.58	0.34

\*Typical Average

## BISPLATE® 450

BISPLATE® 450 is a through hardened, abrasion resistant steel plate, with very good toughness, weldability and formability, offering long life expectancy in sliding and gouging abrasion applications, with impact loading.

### APPLICATIONS

BISPLATE® 450 offers exceptionally long life in high abrasion applications with impact loading. Applications include:

- Dump truck wear liners/bodies
- Mining buckets
- Tipper bodies
- Cutting edges
- Construction waste bins
- Liner plates/chutes

### FABRICATION

BISPLATE® 450 is a low carbon, high hardness, abrasion resistant steel with guaranteed impact toughness. BISPLATE® 450 can be successfully welded to itself and a range of other steels by conventional techniques. Because of its high hardness, cold forming of BISPLATE® 450 requires higher bending and forming forces and greater allowances must be made for springback. Heating above 200°C should be avoided, otherwise mechanical properties might be affected.

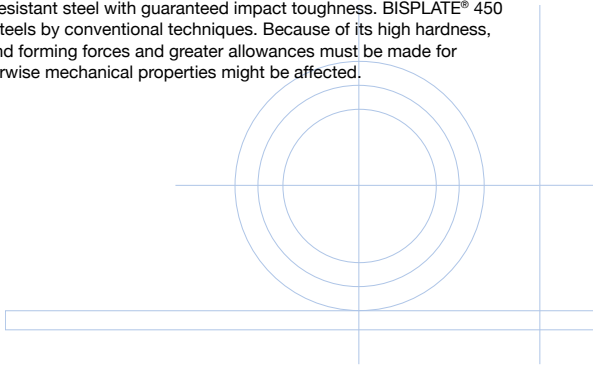

## BISPLATE® 450

### MECHANICAL PROPERTIES

PROPERTIES	SPECIFICATION	TYPICAL
0.2% Proof Stress	-	1150 MPa
Tensile Strength	-	1400 MPa
Elongation in 50mm G.L.	-	12%
Hardness	425 - 475HB	450HB

### GUARANTEED CHARPY-V IMPACT TOUGHNESS

THICKNESS (mm)	TEST PIECE	MIN. ENERGY, LONGITUDINAL -40°C
6 - 8	10 x 5	17J
10	10 x 7.5	21J
12 - 20	10 x 10	25J
>20 - 40	10 x 10	20J
>40 - 50	10 x 10	15J

### CHEMICAL COMPOSITION

THICKNESS (mm)		C	P	Mn	Si	S	Ni	Cr	Mo	B	CE(IIW)*	CET*
6 - 20	Maximum	0.23	0.025	1.00	0.60	0.008	0.25	1.00	0.25	0.002	0.46	0.30
25 - 50	Maximum	0.25	0.025	1.20	0.60	0.008	0.25	1.20	0.35	0.002	0.58	0.36

\*Typical Average

## BISPLATE® 500

BISPLATE® 500 is a through hardened, abrasion resistant steel plate, offering long life expectancy in sliding and gouging abrasion applications.

### APPLICATIONS

BISPLATE® 500 is the hardest steel produced by Bisalloy Steels and offers exceptionally long life in sliding abrasion applications such as:

- Dump truck wear liners
- Chutes
- Wear liners
- Earthmoving buckets
- Cutting edges
- Ground engaging tools

### FABRICATION

BISPLATE® 500 is a medium carbon, high hardness, abrasion resistant steel. With appropriate attention to heat input, preheat and consumable selections, BISPLATE® 500 can be successfully welded to itself and a range of other steels by conventional techniques. Because of its high hardness, cold forming of BISPLATE® 500 is difficult, requiring higher bending and forming forces, and greater allowances must be made for springback. If heating is necessary, this should not exceed 200°C, otherwise mechanical properties might be affected.

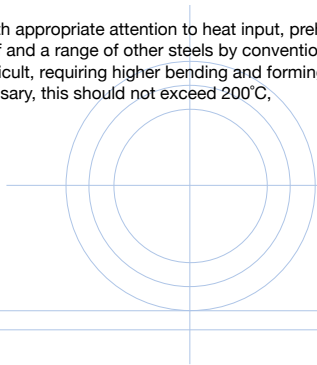

## BISPLATE® 500

### MECHANICAL PROPERTIES

PROPERTIES	SPECIFICATION	TYPICAL
0.2% Proof Stress	–	1400 MPa
Tensile Strength	–	1640 MPa
Elongation in 50mm G.L.	–	10%
Charpy Impact (Longitudinal) +20°C (10mm x10mm)	–	35J
Hardness	477 - 534HB	500HB

### CHEMICAL COMPOSITION

THICKNESS (mm)		C	P	Mn	Si	S	Ni	Cr	Mo	B	CE(IIW)*	CET*
8 - 100	Maximum	0.32	0.025	0.40	0.35	0.008	0.35	1.20	0.30	0.002	0.62	0.40

\*Typical Average

# BISPLATE® HIGH HARDNESS ARMOUR PLATE

## INTRODUCTION

BISPLATE® High Hardness Armour (BISPLATE® HHA) is a quenched and tempered steel armour plate suitable for use in both military and civil applications where light weight and resistance to ballistic projectiles is required.

## METHOD OF MANUFACTURE

BISPLATE® HHA is a hot rolled steel product that is subsequently heat treated to promote its high strength and toughness, high hardness and ballistics properties.

## BRINELL HARDNESS

THICKNESS (mm)	SPECIFICATION	TYPICAL
5 - 50*	477 - 534HB	500HB

\*Other thicknesses may be available on request

## TENSILE PROPERTIES

PROPERTY	TYPICAL
0.2% Proof Stress	1350 MPa
Tensile Strength	1640 MPa
Elongation in 50mm G.L.	14%

## CHARPY IMPACT VALUES

THICKNESS (mm)	TEST PIECE	TEST TEMP	MIN. ENERGY (TRANSVERSE)	MIN. ENERGY (LONGITUDINAL)
5	10 x Thk	-40°C	By Agreement	By Agreement
6 - <9.5	10 x 5	-40°C	8J	10J
9.5 - <12	10 x 7.5	-40°C	12J	15J
≥12	10 x 10	-40°C	16J	20J

# BISPLATE® HIGH HARDNESS ARMOUR PLATE

## MECHANICAL TEST FREQUENCIES

TEST	FREQUENCY
Hardness	Per Plate
Charpy (L)	Per Batch
Charpy (T)	Per Batch
Tensile Testing	By Agreement
Thickness Testing	Per Plate
Ballistic Testing	By Agreement

## CHEMISTRY

The chemical specification conforms with the requirements of MIL-DTL-46100, although it is tighter than the requirements of that specification so as to optimise the material's performance. Product chemical analyses are taken on a per-heat basis.

Chemical analysis is as follows:

## CHEMICAL COMPOSITION

THICKNESS (mm)		C	P	Mn	Si	S	Ni	Cr	Mo	B	CE(IIW)*	CET*
5 - 50 <sup>1</sup>	Maximum	0.32	0.025	0.80	0.50	0.005	0.50	1.20	0.30	0.002	0.61	0.40

\*Note: Nickel and Vanadium are intentionally added.

\*Typical Average

<sup>1</sup> Other thicknesses may be available on request.

## BALLISTIC PROPERTIES

### AS 2343 PART 2

#### BULLET RESISTANT PANELS FOR INTERIOR: OPAQUE PANELS

CLASS	CALIBRE	AMMUNITION	MEASURED VELOCITY @ DISTANCE FROM MUZZLE	RANGE	MINIMUM REQUIRED HHA THICKNESS
G2	44 Magnum	15.6g Lead Semi-Wad Cutter Bullet	488 ± 10m/s @ 1.5m	3m	6mm <sup>2</sup>
S0	12 Gauge (Full Choke)	12 Gauge 70mm High Velocity Magnum 32g SG Shot	403 ± 10m/s @ 1.5m	3m	6mm <sup>2</sup>
S1	12 Gauge (Full Choke)	12 Gauge 70mm 24.8g Single Slug	477 ± 10m/s @ 1.5m	3m	6mm <sup>2</sup>
R1	5.56mm	M193 5.56mm 3.6g Full Metal Case Bullet	980 ± 15m/s @ 5m	10m	10mm <sup>2</sup>
R2	7.62mm	Nato Standard 7.62mm 9.3g Full Metal Case Bullet	853 ± 10m/s @ 5m	10m	6mm

<sup>2</sup> Standard thicknesses produced. Minimum thickness required is less than stated thickness. Please contact Bisalloy for further information.

Class G – Hand Gun    Class S – Shotgun    Class R – Rifles

## RESIDUAL MAGNETISM

Maximum residual magnetism of BISPLATE® armour grades is 50 Gauss when plates are despatched. Special arrangement can be made to limit the maximum residual magnetism to 20 Gauss.

## GRADE EQUIVALENTS

GRADE	COUNTRY OF ORIGIN	STEEL STANDARD	COMMENTS
60	Australia	AS3597 - Grade 500	Min. yield 500MPa
60	ISO	ISO4950-3 AMD 1	Min. yield 500MPa
60	Japan	JIS G3106 SM570	Min. yield 420MPa
60	USA	ASTM A572/A537M-07 Grade 60	Min. yield 415MPa
60	USA	ASTM A537/A537M-08	Min. yield 485MPa
60	Europe	EN10025 S460	Min. yield 460MPa
70	Australia	AS3597 Grade 600	Min. yield 600MPa
70	ISO	ISO4950-3 AMD 1	Min. yield 620MPa
70	USA	ASTM A533/A533M-09 Cl.1	Min. yield 550MPa
70	Europe	EN10025 S600	Min. yield 620MPa
80	Australia	AS3597 Grade 700	Min. yield 690MPa
80	ISO	ISO4950-3 AMD 1	Min. yield 690MPa
80	USA	ASTM A514/A514M-05	Min. yield 690MPa
80	Europe	EN10025 S690	Min. yield 690MPa
80	Japan	JIS G3128	Min. yield 685MPa
80PV	Australia	AS3597 Grade 700PV	Min. yield 690MPa
80PV	USA	ASTM A577/A517M-10	Min. yield 690MPa
80PV	Europe	EN10028 P690	Min. yield 690MPa

## SUMMARY TABLES

### STRUCTURAL STEEL GRADES

STEEL GRADE	PLATE THICKNESS (mm)	CARBON EQUIVALENT (IIW)	BRINELL HARDNESS (HB 3000/10)	MECHANICAL PROPERTIES							
				TENSILE				CHARPY V-NOTCH IMPACT			
				PLATE THICKNESS (mm)	0.2% PROOF STRESS (MPa) Min	TENSILE STRENGTH (MPa)	% ELONGATION (50mm G.L) Min	PLATE THICKNESS (mm)	ENERGY (J) (Min)	TEST TEMP. (°C)	TEST DIRECTIONS
BISPLATE® 60 (AS 3597 Grade 500)	5 - <16	0.40	210	5 - 100	500	590 - 730	20	5	By Agmnt	-20	L
	≥16 - 80	0.50						6 - 9.5	45	-20	L
	>80 - 100	0.58						9.5 - 12	60	-20	L
									13 - 100	80	-20
BISPLATE® 70 (AS 3597 Grade 600)	5 - <16	0.40	230	5 - 100	600	690 - 830	20	5	By Agmnt	-20	L
	≥16 - 80	0.50						6 - 9.5	40	-20	L
	>80 - 100	0.58						9.5 - 12	60	-20	L
									13 - 100	75	-20
BISPLATE® 80 (AS 3597 Grade 700)	5 - <16	0.40	255	5	650	750 - 900	18	5	By Agmnt	-20	L
	≥16 - 80	0.50		6 - 65	690	790 - 930	18	6 - 9.5	20	-20	L
	>80 - 100	0.58		70 - 100	620	720 - 900	16	9.5 - 12	30	-20	L
								13 - 100	40	-20	L
BISPLATE® 80PV (AS 3597 Grade 700PV)	≥6 - 80	0.50	255	6 - 65	690	790 - 930	18	6 - 100	Lateral Expansion 0.38mm min.	By Agmnt max. 0°C	T
	>80 - 100	0.58		70 - 100	620	720 - 900	16				



## SUMMARY TABLES

### HIGH HARDNESS STEEL GRADES

STEEL GRADE	PLATE THICKNESS (mm)	CARBON EQUIVALENT (IIV)	BRINELL HARDNESS (HB 3000/10)	MECHANICAL PROPERTIES					
				TENSILE			CHARPY V-NOTCH IMPACT		
				0.2% PROOF STRESS (MPa)	TENSILE STRENGTH (MPa)	% ELONGATION (50mm G.L.)	ENERGY (J)*	TEST TEMP. (°C)	TEST DIRECTIONS
BISPLATE® 320	5 - <16	0.40	320 - 360	970	1070	18	60	+20	L
	≥16 - 80	0.50							
	>80 - 100	0.58							
BISPLATE® 400	5 - <16	0.40	370 - 430	1070	1320	14	55	+20	L
	≥16 - 80	0.50							
	>80 - 100	0.58							
BISPLATE® 450	6 - 20	0.46	425 - 475	1150	1400	12	25	-40	L
	25 - 40	0.58					20		
	>40 - 50						15		
BISPLATE® 500	6 - 100	0.62	477 - 534	1400	1640	10	35	+20	L

\*Note: Charpy energy values are for 10 x 10mm specimen sizes.

#### Legend

- L Longitudinal  
 T Transverse  
 Guaranteed Values  
 Typical Average Values (provided for reference information only)

IIV Carbon Equivalent Formula:

$$C.E. = C + \frac{Mn}{6} + \frac{Cr+Mo+V}{5} + \frac{Ni+Cu}{15}$$

$$C.E.T = C + \frac{(Mn+Mo)}{10} + \frac{(Cr+Cu)}{20} + \frac{Ni}{40} = [\%]$$

## BISPLATE® SIZE RANGE

### STANDARD SIZE SCHEDULE

Table 1:

PLATE MASS IN TONNES												
GRADE	BISPLATE® 60, 70, 80, 320, 400						BISPLATE® 450		BISPLATE® 500			
WIDTH (mm)	1525	1900	2485	1525	2485	3100	2485	3100	1525	1900	2485	2485
LENGTH (m)	6000	6000	6000	8000	8000	8000	8000	8000	6000	6000	6000	8000
Thickness (mm)												
5				0.479								
6				0.575	0.936		0.936					
8					1.248		1.248					1.248
10					1.561	1.947	1.561	1.947				1.561
12					1.873	2.336	1.873	2.336				1.873
16					2.497	3.115	2.497	3.115				2.497
20					3.121	3.894	3.121	*4.040				3.121
25					3.901	4.867	3.901	**5.354				3.901
32					4.994		*5.306					4.994
40					6.242		6.242					6.242
50					7.803		7.803					7.803
60			7.023								7.023	
70		6.264								6.264		
75		6.712							5.387			
80		7.159							5.746			
90	6.464								6.464			
100	7.183								7.183			

### NON STANDARD SIZES

- Available subject to sales enquiry.
- Minimum order quantities may apply.

Plate mass (tonnes) calculation =  $7.85 \times W \times T \times L$  (m)

### EDGE CONDITION

- All plate 1525mm wide and 5 & 6mm thick is supplied with untrimmed edge.
- All other plate is supplied with trimmed edge.

## MANUFACTURING TOLERANCES

### THICKNESS TOLERANCE

Table 1:

WIDTH		THICKNESS (+ / - mm)									
		≤6	>6 ≤8	>8 ≤10	>10 ≤13	>13 ≤18	>18 ≤22	>22 ≤30	>30 ≤42	>42 ≤63	>63
≥1600	<1600	0.53	0.60	0.60	0.68	0.83	0.90	1.05	1.28	1.73	2.55
	<2100	0.60	0.68	0.68	0.75	0.90	0.98	1.13	1.35	1.80	2.63
≥2100	<2700	0.75	0.75	0.83	0.90	0.98	1.125	1.28	1.50	1.95	-
≥2700		-	0.98	1.05	1.13	1.20	1.35	1.43	-	-	-

- Notes: 1. Measurement can be conducted anywhere on plate.  
2. All dimensions are in millimetres.

### WIDTH TOLERANCE TRIMMED EDGE PLATE

Table 2:

THICKNESS	<16		≥16 <50		≥50	
WIDTH	PLUS	MINUS	PLUS	MINUS	PLUS	MINUS
<1520	20	0	25	0	25	0
≥1520	20	0	30	0	30	0

Note: All dimensions are in millimetres.

## UNTRIMMED EDGE PLATE

Table 3:

WIDTH (ALL THICKNESS)	PLUS	MINUS
$\leq 1500$	40	0

Note: All dimensions are in millimetres.

## LENGTH TOLERANCE

Table 4:

ALL THICKNESS	<25		$\geq 25$	
LENGTH	PLUS	MINUS	PLUS	MINUS
<6000	25	0	30	0
$\geq 6000 < 12000$	30	0	40	0
$\geq 12000$	50	0	65	0

Note: All dimensions are in millimetres.

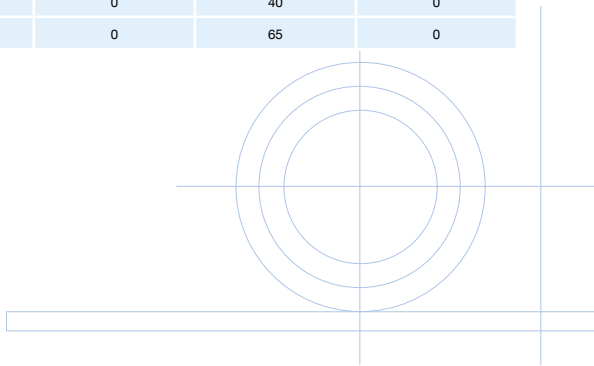

## CAMBER EDGE CAMBER TOLERANCE

Table 5:

SPECIFIED WIDTH	TRIMMED EDGE	UNTRIMMED EDGE
ALL	4	6

Note: All dimensions are in millimetres

Figure 1:

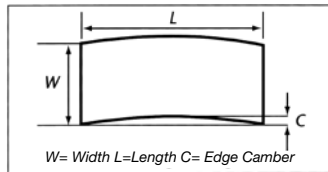

Note: All dimensions are in millimetres

Edge Camber shall be limited so that it shall be possible to inscribe the dimensions of the ordered plate within the delivered size.

## FLATNESS

Measurement of flatness tolerance should be made when the product, resting under its own mass, is placed on a flat horizontal surface.

A straight edge shall be placed on the plate and the maximum vertical distance from the plate shall be measured (H).

Figure 2a:

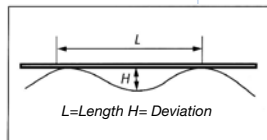

Measurement of Flatness - Waviness.

Figure 2b:

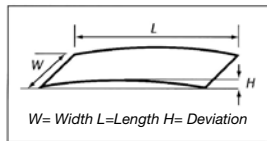

Measurement of Flatness - Bowing.

## BISALLOY MANUFACTURING TOLERANCES

Table 6:

SPECIFIED THICKNESS PLATE (mm)	DISTANCE BETWEEN POINTS OF CONTACT (mm)	SPECIFIED WIDTH OF PLATE (mm)				
		<1500	≥1500 <1800	≥1800 <2400	≥2400 <3000	≥3000
≤6	1000	8	8	8	10	15
	2000	15	15	15	25	30
>8 ≤12	1000	6	6	8	10	15
	2000	10	10	15	20	25
>12 ≤25	1000	6	6	6	10	10
	2000	8	10	12	16	16
>25	1000	6	6	6	6	6
	2000	8	8	10	10	10

### Notes:

1. The tolerances apply when measured at least 20mm from the longitudinal edges and 100mm from the transverse edges.
2. Where the distance between the points of contact is between 500mm and 1000mm, the permissible deviation is obtained as follows.

$$\frac{\text{DISTANCE BETWEEN POINTS OF CONTACT} \times H}{1000}$$

Where H = allowable deviation for 1000mm

Note: This table is an extract of the AS1365 (table 3.4).

However Bisalloy internal manufacturing tolerances are considerably more restrictive.

3. All dimensions are in millimetres.

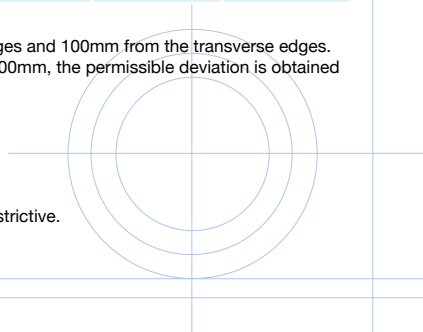

## CUTTING BISPLATE®

### FLAME CUTTING, PLASMA CUTTING, LASER CUTTING, WATERJET CUTTING AND SAWING RECOMMENDATIONS

All grades of BISPLATE® quenched and tempered steel can be cut by either thermal cutting, laser cutting, waterjet cutting or power saw operations. The cutting operations can be carried out either in the workshop or, in the case of flame cutting, in field conditions. Both the high strength structural grades and the wear and abrasion resistant grades can be cut using the same type of equipment employed in cutting plain carbon steels.

Figure 1a:

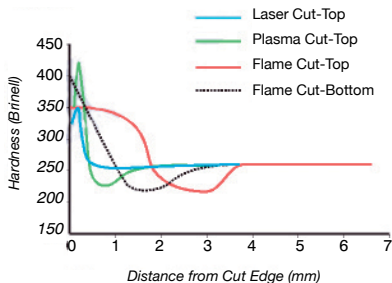

Effects of flame, plasma and laser cutting on plate hardness for a 6mm AS3597 Grade 700 steel (BISPLATE® 80). Hardness tests were conducted using the Vickers method and converted to Brinell hardness values (HB).

## CUTTING OPERATIONS

Dependant on the grade and thickness being cut, the following operations can be used on BISPLATE® grades.

Flame Cutting (Oxy-LPG and Oxy-acetylene)

Plasma Cutting

Laser Cutting

Waterjet Cutting

Power Sawing

Figure 1b:

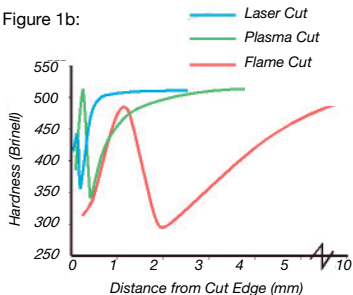

Effects of flame, plasma and laser cutting on plate hardness for a 6mm BISPLATE® 500. Hardness tests were conducted using the Vickers method and converted to Brinell hardness values (HB).

Note: Some variations to the hardness profiles of fig: 1a and 1b will occur with changes to cutting speed and plate thickness.

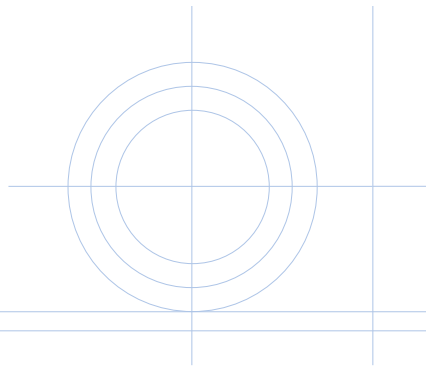

## FLAME CUTTING

Both Oxy-LPG and Oxy-acetylene processes are acceptable for sectioning all thicknesses of BISPLATE®. With these processes, the following techniques are recommended:

- Gas pressure to be the same as for cutting the equivalent thickness in plain carbon steel
- Reduce travel speeds by 30% when compared to the equivalent thickness plain carbon steels when using a standard cutting nozzle
- Nozzle size to be the same as for equivalent thickness plain carbon steel
- Correct selection of nozzle size for the plate thickness being cut is important to ensure efficient cutting and to minimise the width of the heat affected zone (HAZ)

As with all plate steels, the smoothness of the cut is affected by surface scale. If this is present, it is advisable to remove it prior to cutting (BISPLATE® is normally supplied in the shotblasted condition).

Under normal Oxy cutting conditions, the total heat affected zone adjacent to the flame cut edge will extend into the plate approximately 2-3mm, as shown in figure 1a for BISPLATE® 80. It should be noted that the heat affected zone produces a 'hard' layer adjacent to the flame cut edge, with a 'soft' layer inside this. The original plate hardness returns after the 2-3mm distance from the cut edge. For BISPLATE® 500 the HAZ may extend as much as 4-5mm into the plate as shown in figure 1b.

Preheating BISPLATE® steel prior to flame cutting will minimise the hardness of the flame cut edge and also reduce the risk of delayed cracking from this cut edge. This is particularly important in cold environments where plate temperature is less than 20°C and for the high hardenability grades of BISPLATE® 500.

Table 1 below, gives guidance on the preheat requirements. It is recommended that the zone to be preheated should extend at least 75mm either side of the line of cut, with the temperature being measured on the opposite surface and at a distance of 75mm, as shown in figure 2.

## RECOMMENDED MINIMUM PREHEAT TEMPERATURES FOR FLAME CUTTING OF BISPLATE® GRADES

Table 1:

BISPLATE® GRADE	PLATE THICKNESS (mm)	MINIMUM PRE-HEAT TEMPERATURE (°C)
60, 70	8 - 32	20
80, 80PV	5 - 31	20
	32 - 100	50
320, 400	5 - 31	20
	32 - 100	50
450	6 - 20	20
	21 - 50	50
500	8 - 20	50
	21 - 100	100

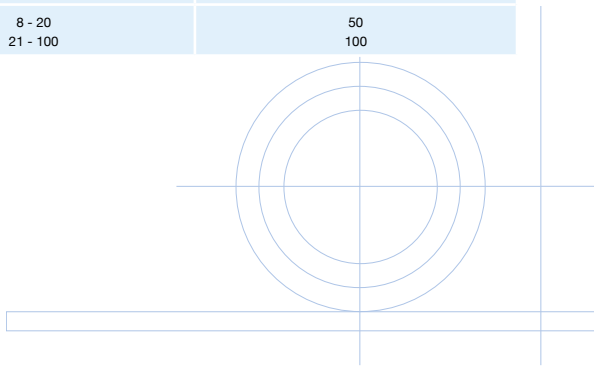
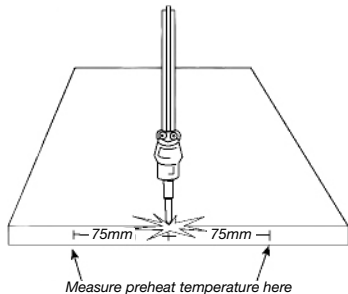

Figure 2: Recommended preheat zone and location of preheat measurement.



If the flame cut surface is to be the face of a welded joint, the heat affected zone from the flame cutting need not be removed. However, all slag and loose scale should be removed by light grinding, and prior to welding, the cut surface should be dry and free from organic matter such as oil, grease, etc (as directed by good workshop practice).

When stripping plates, the use of multiple cutting heads will help to minimise distortion of the cut pieces. Correct nozzle size, gas pressure and travel speed will also minimise distortion during cutting. Softening on edges can also occur when flame cutting small strips, eg. 50mm wide x 50mm thick plate.

Quench cutting of BISPLATE® grades to minimise distortion is not recommended, cooling in still air is preferred. The technique of stacking plates during profile cutting should also be avoided.

For component cutting and/or profiling of small parts an increase in temperature can occur and may affect the mechanical properties of the steel.

## SUMMARY OF FLAME CUTTING RECOMMENDATIONS

- For oxy processes use gas pressures and nozzle sizes as for an equivalent thickness of plain carbon steel
- For oxy processes use cutting speeds two thirds of that recommended for an equivalent thickness of plain carbon steel
- Flame cutting produces a heat affected zone on all grades. The risk of delayed cracking is reduced by using preheat especially for thick plate and for BISPLATE® 500 grade
- Use multiple cutting heads when stripping plates
- Still air cooling after cutting
- Do not stack cut
- Do not quench cut plates
- Use thermal crayons or surface thermometers to measure preheat temperatures

## REFERENCES/FURTHER READING

WTIA Technical Note 5 “Flame Cutting of Steels.”

## PLASMA CUTTING

Plasma cutting is an acceptable method of sectioning all grades of BISPLATE®. The process offers particular advantages of productivity over flame cutting in thicknesses up to 20mm using currently available equipment. For instance, the cutting speed of 6mm BISPLATE® 400 may be up to 9 times that recommended for conventional flame cutting techniques.

The cut quality may be inferior, however, due to rounding of the top edges and difficulty in obtaining a square cut face of both edges. Guidance on the optimum settings for nozzle size, gas pressure, gas composition and cutting speeds will be provided by the equipment manufacturer. BISPLATE® with low alloy contents should be treated similarly to conventional structural steels.

The heat affected zone from a plasma cut is narrower than that produced from flame cutting but peak hardnesses are generally higher. General recommendations for the removal of this hardened zone are outlined below.

## HARDNESS PROFILE CHARACTERISTICS FOR PLASMA CUTTING

Table 2:

PLATE THICKNESS (mm)	RECOMMENDED DEPTH OF REMOVAL (mm)	PEAK HARDNESS (HB)		
		BISPLATE® 60, 70, 80, 320, 400	BISPLATE® 450	BISPLATE® 500
5 - 8	0.4 - 0.5	430	480	540
>8 - 12	0.6 - 0.8	450	480	540
>12 - 20	1.0 - 1.2	450	480	540

The plasma cut HAZ typically extends 0.5 – 1.0mm into the plate under normal conditions. As is the case for flame cutting, complete removal by grinding is recommended if cold forming of the cut plate is contemplated.

All other comments for flame cutting regarding preheating, removal of the HAZ, stripping and stack cutting of plates would apply to plasma cutting.

## LASER CUTTING

Laser cutting is a productive method for sectioning all grades of BISPLATE® up to 12mm thickness, particularly where high levels of accuracy and minimal distortion is required. Currently, with thicknesses above 12mm, productivity levels drop when compared with other processes.

The laser cutting process is unlike other thermal cutting in so far as the material is essentially vapourised from the kerf rather than melting and removal by kinetic energy.

The laser concentrates its energy into a focused beam resulting in low levels of excess heat. This results in very small HAZ areas (0.05 – 0.15mm) and small kerfs (0.3mm).

### COMPARISON OF FLAME, PLASMA AND LASER CUTTING ON 6MM BISPLATE® 400

Table 3:

PROCESS	KERF WIDTH (mm)	HAZ WIDTH (mm)
Flame cutting	0.9	1.5
Plasma cutting	3.2	0.5
Laser Cutting	0.3	0.2

Cutting speeds are typically 5000mm/min and the edge is generally square, burr free and minimal dross.

Peak hardness levels are lower than those obtained from alternate cutting methods previously described. Removal of the HAZ is generally not considered necessary for most applications, however, for forming operations it is advised that Bisalloy Steels® are contacted for guidance.

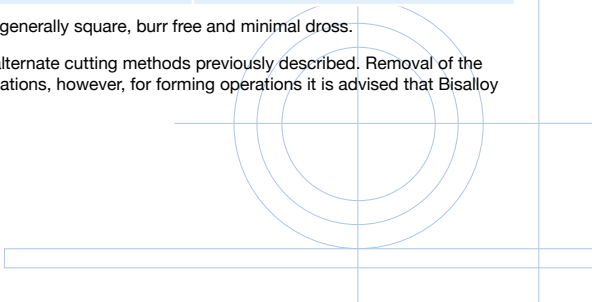

## POWER SAWING

All BISPLATE® grades can be cut with power saws, provided lower blade speeds and blade pressures up to 50% higher than those used for cutting plain carbon steel are used. Best results have been achieved using power saw blades normally recommended for cutting stainless steel (generally, blades having 4-6 teeth per 25mm). Sawing directly onto a flame cut surface should be avoided where possible.

## WATERJET CUTTING

Waterjet cutting can be performed on all grades of BISPLATE®, although its widespread use is limited due to the current machines available in Australia and their low cutting speeds.

A key advantage of water jet cutting is that it leaves the surface free of HAZ. Cutting without heat protects against metallurgical changes in the plate, ensuring original plate mechanical properties are maintained.

Recent tests performed by the CSIRO Division of Manufacturing Technology on waterjet cutting 8mm BISPLATE® 500 at 40mm/min resulting in near perfect cut edges. Speeds to 75mm/min are possible but with reduced smoothness of the cut edge.

The waterjet cut shows no change in material structure at the edge of the cut. The laser cut edge shows a distinct change in structure to a depth of 0.2mm.

Both laser cutting and waterjet cutting are industrial processes which should be considered by structural designers and fabricators as alternate means to avoiding problems associated with fit up, cut edge squareness, shape precision, dross and gross HAZ's which can occur with conventional thermal cutting processes.

Bisalloy Steels® wish to thank the Australian Welding journal, CSIRO-DMT, Ian Henderson, CRC for Materials Welding and joining and Rory Thompson, CSIRO Industry Liaison Manager for information pertaining to laser and waterjet cutting contained in this publication.

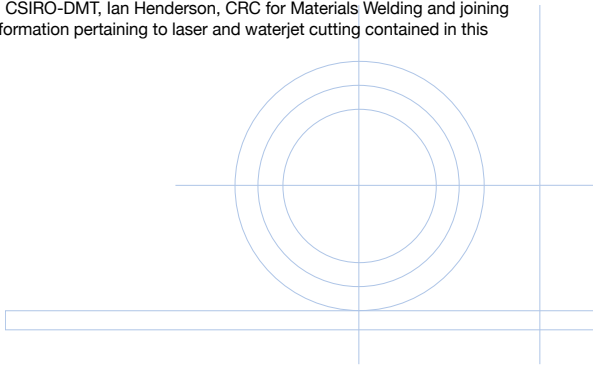

## WELDING OF BISPLATE® QUENCHED AND TEMPERED STEELS

### GENERAL INFORMATION

All grades of BISPLATE® can be readily welded using any of the conventional low hydrogen welding processes.

Their low carbon content and carefully balanced, but relatively small additions of alloying elements (Mn, Cr, Mo, Ni, B) ensures good weldability, in addition to the advantages of high strength, impact toughness and high hardness.

### HYDROGEN CONTROL

To ensure adequate welding of BISPLATE®, it is necessary to be more mindful of the levels of hydrogen, preheat temperatures and arc energy inputs in order to minimise the hardening and maintain the properties of the weld Heat Affected Zone (HAZ).

Particular attention must be paid to the control of hydrogen content to minimise the risk of weld and HAZ cracking.

Weld hydrogen content is minimised by careful attention to the cleanliness and dryness of the joint preparations and the use of hydrogen controlled welding consumables.

Recommendations on the correct storage and handling of consumables may be obtained from welding consumable manufacturers, for instance the use of “Hot Boxes” for storage and reconditioning are required when using manual metal arc welding electrodes. Refer WTIA Tech Note 3 for further guidance.

### HEAT AFFECTED ZONE PROPERTY CONTROL

The HAZ, a region directly adjacent to the weld, experiences a thermal cycle ranging from unaffected parent plate to near melting at the fusion boundary.

The properties of this zone are determined by the steel composition as well as the cooling rate.

## STEEL COMPOSITION

BISPLATE® grades and chemical compositions may be divided into categories based on Carbon Equivalent and CET as follows:

Table 1:

BISPLATE® GRADE	PLATE THICKNESS (mm)	CARBON EQUIVALENT (IIW) TYPICAL AVERAGE	CET TYPICAL AVERAGE
60, 70, 80, 320, 400	5 - 12	0.40	0.29
60, 70, 80, 320, 400	13 - 80	0.50	0.35
60, 70, 80, 320, 400	81 - 100	0.58	0.34
450	6 - 20	0.46	0.30
	25 - 50	0.58	0.36
500	8 - 100	0.62	0.42

Notes:

- $$\text{C.E. (IIW)} = \text{C} + \frac{\text{Mn}}{6} + \frac{\text{Cr} + \text{Mo} + \text{V}}{5} + \frac{\text{Cu} + \text{Ni}}{15}$$
- $$\text{CET} = \text{C} + \frac{\text{Mn} + \text{Mo}}{10} + \frac{\text{Cr} + \text{Cu} + \text{Ni}}{20} + \frac{\text{Ni}}{40}$$

These categories give an indication of the degree of care required in the proper selection of welding preheat/heat inputs.

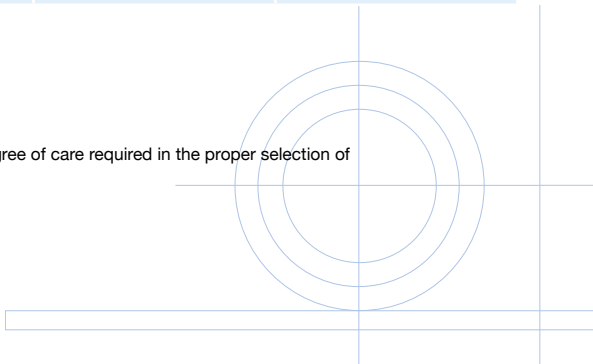

## COOLING RATE

Limitations on both preheat and heat input are necessary to ensure that the HAZ cools at an appropriate rate and that the correct hardness and microstructure are achieved. Too slow a cooling rate can result in a soft HAZ and thus a loss of tensile and fracture toughness properties. Too rapid a cooling rate produces a hard HAZ which may cause loss of ductility. Cooling is controlled by a balance between preheat and heat input for a particular plate thickness and joint configuration.

## PREHEAT/HEAT INPUT

The preheat/heat input recommendations outlined in tables 2 and 3 will ensure that the cooling rate of the HAZ is satisfactory.

## RECOMMENDED PREHEAT/INTERPASS TEMPERATURES (°C) FOR BISPLATE®

Table 2:

BISPLATE® GRADE	JOINT COMBINED THICKNESS ( $t_1 + t_2 + t_3$ ) MM				
	<30	≥30≤40	>40<50	≥50<100	≥100
Minimum Preheat Temp°C High Strength Structural Grades					
60 (AS 3597 Grade 500)	Nil*	50	50	75	140
70 (AS 3597 Grade 600)	Nil*	50	50	75	140
80 (AS 3597 Grade 700)	Nil*	50	50	75	140
Minimum Preheat Temp°C Abrasion Resistant Grades					
320	Nil*	75	75	125	150
400	Nil*	75	75	125	150
450	Nil*	Nil*	100	125***	**
500	100	150	150	150	**
Maximum Interpass Temp°C					
80 - 450 Grades	150	150	175	200	220
500 Grade	150	175	175	200	220

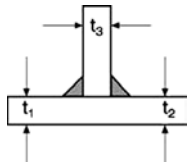

\* Chill must be removed from plates prior to welding.

\*\* Refer to Bisalloy Steels® for availability, preheat/interpass requirements.

\*\*\* A reduced 100°C min preheat can be used for product ≥50 – 60 JCT.

Note that under rigid weld joint restraint or high ambient humidity conditions preheating temperature should be increased by 25°C.

## PERMISSIBLE HEAT INPUT (KJ/MM) FOR BISPLATE®

Table 3:

WELDING PROCESS	JOINT COMBINED THICKNESS ( $t_1 + t_2 + t_3$ ) mm			
	≤40	>40 ≤60	>60 ≤100	>100
MMAW	1.25 - 2.5	1.25 - 3.5	1.5 - 4.5	1.5 - 5.0
GMAW	1.0 - 2.5	1.0 - 3.5	1.5 - 4.5	1.5 - 5.0
FCAW	0.8 - 2.5	0.8 - 3.5	1.5 - 4.5	1.5 - 5.0
SAW	1.0 - 2.5	1.0 - 3.5	1.5 - 4.5	1.5 - 5.0

$$\text{Heat input (kJ/mm)} = \frac{\text{Volts} \times \text{Amps} \times 0.06}{\text{Travel Speed (mm/minute)}}$$

Note: For thicknesses up to 12mm in structural grades, the maximum arc energy may need to be limited to 1.5 KJ/ mm maximum in specific applications.

## WELDING BISPLATE®

### WELDING CONSUMABLE SELECTION GUIDE FOR BISPLATE® (AS CLASSIFICATIONS)

Table 4a:

		BISPLATE® 60	BISPLATE® 70	BISPLATE® 80	BISPLATE® 320, 400, 450, 500
MMAW Consumables <sup>1</sup> Warning: Only use Hydrogen Controlled consumables					
Strength Level	Matching Lower Lower	E55XX/E62XX* E48XX E48XX	E69XX* E55XX E48XX	E76XX E55XX/E62XX E48XX N.R.	N.R. E55XX E48XX
Hardness	Matching	N.R.	N.R.	N.R.	1430-AX, 1855-AX**
GMAW Consumables <sup>2</sup>					
Strength Level	Matching Lower Lower	W55XX/W62XX* W50XX W50XX	W69XX* W55XX W50XX	W76XX W62XX/W69XX W55XX.X N.R.	N.R. W55XX W50XX
Hardness	Matching	N.R.	N.R.	N.R.	1855-BX**
FCAW Consumables <sup>3</sup>					
Strength Level	Matching Lower Lower	W55XX.X/W62XX.X* W50XX.X W50XX.X	W69XX.X* W62XX.X W55XX.X	W76XX.X W62XX.X W55XX.X N.R.	N.R. W55XX.X W50XX.X
Hardness	Matching	N.R.	N.R.	N.R.	1430-BX, 1855-BX, 1860-BX**
SAW Consumables <sup>4</sup>					
Strength Level	Matching Lower Lower	W55XX/W62XX* W50XX W40XX	W69XX* W50XX W40XX	W76XX W50XX W40XX N.R.	N.R. W50XX W40XX
Hardness	Matching	N.R.	N.R.	N.R.	1855-BX**

Table 4a courtesy of WTIA (Tech Note 15)

Notes:

1. MMAW - AS/NZS 4855 consumable classification.
2. GMAW - AS2717.1 consumable classification.
3. FCAW - AS/NZS 17632 and AS/NZS 18276 consumable classification.
4. SAW - AS1858.1 and AS1858.2 consumable classification.

X = A Variable - any value allowed by the relevant standard may be acceptable provided that the consumable is hydrogen controlled (ie low hydrogen).

+ E62XX and W62XX type consumables overmatch the strength requirements but may be used.

\* These Consumables may be difficult to obtain. In some cases E62XX or W62XX type consumables may be substituted, otherwise use E76XX or W76XX types.

\*\* AS2576 and WTIA TN 4 Classifications.

N.R. – Not Recommended.

## WELDING CONSUMABLE SELECTION GUIDE FOR BISPLATE® (AWS CLASSIFICATIONS)

Table 4b:

		BISPLATE® 60	BISPLATE® 70	BISPLATE® 80	BISPLATE® 320, 400, 450, 500
MMAW Consumables <sup>1</sup> Warning: Only use Hydrogen Controlled consumables					
Strength Level	Matching Lower Lower	E80XX/E90XX* E70XX E70XX	E100XX* E80XX E70XX	E110XX E80XX/E90XX E70XX N.R.	N.R. E80XX E70XX
Hardness	Matching	N.R.	N.R.	N.R.	1430-AX, 1855-AX**
GMAW Consumables <sup>2</sup>					
Strength Level	Matching Lower Lower	ER80S-X/ER90S-X* ER70S-X ER70S-X	ER100S-X* ER80S-X ER70S-X	ER110S-X ER90S-X/ER100S-X ER80S-X N.R.	N.R. ER80S-X ER70S-X 1855-BX**
Hardness	Matching	N.R.	N.R.	N.R.	
FCAW Consumables <sup>3</sup>					
Strength Level	Matching Lower Lower	E8XTX-X/E9XTX-X* E7XTX-X E7XTX-X	E10XTX-X* E9XTX-X E8XTX-X	E11XTX-X E9XTX-X E8XTX-X N.R.	N.R. E8XTX-X E7XTX-X
Hardness	Matching	N.R.	N.R.	N.R.	1430-BX, 1855-BX, 1860-BX**
SAW Consumables <sup>4</sup>					
Strength Level	Matching Lower Lower	F8XX/F9XX* F7XX F6XX	F10XX* F7XX F6XX	F11XX F7XX F6XX N.R.	N.R. F7XX F6XX
Hardness	Matching	N.R.	N.R.	N.R.	1855-BX**

Table 4b courtesy of WTIA (Tech Note 15)

Notes:

1. MMAW – AWS A5.1-91 and AWS A5.5-81 consumable classification.
2. GMAW – AWS A5.18-93 and AWS A5.28-79 consumable classification.
3. FCAW – AWS A5.20-79 and AWS A5.29-80 consumable classification.
4. SAW – AWS A5.17-89 and AWS A5.23-90 consumable classification.

X = A Variable - any value allowed by the relevant standard may be acceptable provided that the consumable is hydrogen controlled (ie low hydrogen).

+ E90XX, ER90S, E9XTX and F9XX type consumables overmatch the strength requirements but may be used.

\*These Consumables may be difficult to obtain. In some cases E90XX, ER90S, E9XTX or F9XX type consumables may be substituted, otherwise use E110XX, ER110S, E11XTX or F11XX types.

\*\*AS2576 WTIA TN 4 Classifications.

N.R. – Not Recommended.

## **MANUFACTURERS' WELDING CONSUMABLES**

Welding Consumables suitable for matching strength, lower strength and matching hardness are readily available from a range of consumable manufacturers as per following tables 5 to 8.

## WELDING CONSUMABLES FOR MANUAL METAL ARC WELDING (MMAW)

Table 5:

BRANDS		BISPLATE® 60	BISPLATE® 70	BISPLATE® 80	BISPLATE® 320, 400, 450, 500
CIGWELD	M.S.	Alloycraft 90	Alloycraft 90 (under) Alloycraft 110 (over)	Alloycraft 110	N.R.
	L.S.	Ferrocrafft 61 Ferrocrafft 16 Twincoat	Ferrocrafft 61 Ferrocrafft 16 Twincoat	Ferrocrafft 61 Ferrocrafft 16 Twincoat	Ferrocrafft 61 Ferrocrafft 16 Twincoat
	M.H.	N.R.	N.R.	N.R.	Cobalarc 350, 650, 750
Lincoln Electric	M.S.	SL 20G	Conarc 80*	Conarc 80	N.R.
	L.S.	Conarc 49C Jetweld LH70	Conarc 49C Jetweld LH70	Conarc 49C Jetweld LH70	Conarc 49C Jetweld LH70
	M.H.	N.R.	N.R.	N.R.	N.R.
W.I.A	M.S.	N.R.	Weldwell PH118	Weldwell PH118	N.R.
	L.S.	Austarc 16TC, 18TC or Austarc 77	Austarc 16TC, 18TC Austarc 77	N.R.	Austarc 16TC, 18TC Austarc 77
	M.H.	N.R.	N.R.	N.R.	Abraso Cord 350, 700
SWP/Metrode Products	M.S.	E9018-D1	E10018-D2	E11018-M	N.R.
	L.S.	MP51	MP51	MP51	MP51
	M.H.	N.R.	N.R.	N.R.	Methard 350, Methard 650
Eutectic Castolin	M.S.	N.A.	N.A.	N.A.	N.R.
	L.S.	Eutectrode 66*66	Eutectrode 66*66	Eutectrode 66*66	Eutectrode 66*66
	M.H.	N.R.	N.R.	N.R.	N.R.
ESAB	M.S.	OK 74.70	OK 74.86	OK 75.75	
	L.S.	OK 48.08, OK 48.04	OK 48.04, OK 48.08	OK 48.08, OK 48.04	
	M.H.	N.R.	N.R.	N.R.	OK 83.28 (30 HRC) OK 83.50 (50-60 HRC)

M.S. – Matching Strength

L.S. – Lower Strength

M.H. – Matching hardness

N.R. – Not Recommended

N.A. – Not available

N.B. – Consumables in brackets will match mechanical property requirements in the majority of instances as per manufacturer's recommendations and where the appropriate weld procedure is applied. Weld Qualification procedures should be carried out to establish actual Weld metal properties.

\*Consumable recommendations overmatch mechanical property requirements.

## WELDING CONSUMABLES FOR GAS METAL ARC WELDING (GMAW)

Table 6:

BRANDS		BISPLATE® 60	BISPLATE® 70	BISPLATE® 80	BISPLATE® 320, 400, 450, 500
CIGWELD/STOODY  Contact Bisalloy or Thermadyne for shielding gas information	M.S.	Autocraft MnMo	Autocraft MnMo (Under) or Autocraft NiCrMo (Over)	Autocraft NiCrMo	N.R.
	L.S.	Autocraft LW1 or Autocraft LW1-6	Autocraft LW1 or Autocraft LW1-6	Autocraft LW1 or Autocraft LW1-6	Autocraft LW1 or Autocraft LW1-6
	M.H.	N.R.	N.R.	N.R.	Autocraft HF650
Lincoln	M.S.	N.R.	SuperArc LA100*	SuperAcr LA100	N.R.
	L.S.	UltraMag S4 UltraMag S6**	UltraMag S4 UltraMag S6**	UltraMag S4 UltraMag S6**	UltraMag S4 UltraMag S6**
	M.H.	N.R.	N.R.	N.R.	N.R.
W.I.A	M.S.	Austmig ESD2/CO <sub>2</sub> or Mixed Gas	Austmig NiCrMo	Austmig NiCrMo	N.R.
	L.S.	Austmig ES6/CO <sub>2</sub> or Mixed Gas	Austmig ES6/CO <sub>2</sub> or Mixed Gas	Austmig ES6/CO <sub>2</sub> or Mixed Gas	Austmig ES6/CO <sub>2</sub> or Mixed Gas
	M.H.	N.A.	N.A.	N.A.	TD600/CO <sub>2</sub> or Mixed gas
Eutectic Castolin	M.S.	AN45252/ CO <sub>2</sub> or Mixed Gas	AN45252/ CO <sub>2</sub> or Mixed Gas	AN45252/ CO <sub>2</sub> or Mixed Gas	N.R.
	L.S.	DO*65/CO <sub>2</sub> or Mixed Gas	DO*65/CO <sub>2</sub> or Mixed Gas	DO*65/CO <sub>2</sub> or Mixed Gas	DO*65/CO <sub>2</sub> or Mixed Gas
ESAB	M.S.	OK AristoRod 13.09 Mixed Gas	OK AristoRod 55 Mixed Gas	OK AristoRod 69 Mixed Gas	
	L.S.	OK AristoRod 12.50 CO <sub>2</sub> or Mixed Gas	OK AristoRod 12.50 CO <sub>2</sub> or Mixed Gas	OK AristoRod 12.50 CO <sub>2</sub> or Mixed Gas	
	M.H.	N.R.	N.R.	N.R.	OK AutoRod 13.89 (30-40HRC) OK AutoRod 13.90 (50-60HRC)

M.S. – Matching Strength

L.S. – Lower Strength

M.H. – Matching hardness

N.R. – Not Recommended

N.A. – Not available

N.B. – Consumables in brackets will match mechanical property requirements in the majority of instances as per manufacturer's recommendations and where the appropriate weld procedure is applied. Weld Qualification procedures should be carried out to establish actual Weld metal properties.

\*Consumable recommendations overmatch mechanical property requirements.

## WELDING CONSUMABLES FOR FLUX CORED ARC WELDING (FCAW)

Table 7:

BRANDS		BISPLATE® 60	BISPLATE® 70	BISPLATE® 80	BISPLATE® 320, 400, 450, 500
CIGWELD/ STOODY	M.S. Seamless	Verticor 91K2 H4	Verticor 91K2 H4 (Under) or *Verticor 111K3 H4 (Over) or Tensicor 110TXP H4 (Over)	*Verticor 111K3 H4 (Over) or Tensicor 110TXP H4 (Over)	N.R.
	L.S. Seamless (E6XT-X)	Verticor XP LT H4	Verticor XP LT H4	Verticor XP LT H4	Verticor XP LT H4
	L.S. Seamless	Verticor 3XPH4 or Verticor 5XP or Metalcor 5 H4 or Verticor 81Ni1 H4	Verticor 3XPH4 or Verticor 5XP or Metalcor 5 H4 or Verticor 81Ni1 H4	Verticor 3XPH4 or Verticor 5XP or Metalcor 5 H4 or Verticor 81Ni1 H4	Verticor 3XPH4 or Verticor 5XP or Metalcor 5 H4 or Verticor 81Ni1 H4
	L.S. Seamed	Verticor 3XP or Suprecor 5 or Metalcor XP or Verticor 81Ni1 or 81Ni2	Verticor 3XP or Suprecor 5 or Metalcor XP or Verticor 81Ni1 or 81Ni2	Verticor 3XP or Suprecor 5 or Metalcor XP or Verticor 81Ni1 or 81Ni2	Verticor 3XP or Suprecor 5 or Metalcor XP or Verticor 81Ni1 or 81Ni2
	L.S. Self Shielded	Shieldcor 8XP or Shieldcor 8Ni	Shieldcor 8XP or Shieldcor 8Ni	Shieldcor 8XP or Shieldcor 8Ni	Shieldcor 8XP or Shieldcor 8Ni
	M.H.	N.R.	N.R.	N.R.	Stoody Super Build-Up or Stoody 965-G or Stoody 965 AP-G
Lincoln	M.S.	Outersield 91Ni1-HSR/20-H	Outersield 20-H	Outersield 690-H	N.R.
	L.S.	Outersield 81Ni, 71MX, 71CX Innersield NR232, NR233, NS3M	Outersield 81Ni, 71MX, 71CX Innersield NR232, NR233, NS3M	Outersield 81Ni, 71MX, 71CX Innersield NR232, NR233, NS3M	Outersield 81Ni, 71MX, 71CX Innersield NR232, NR233, NS3M Lincore 36LS, Lincore 33, Lincore 55-G
	M.H.	N.R.	N.R.	N.R.	
W.I.A./Hobart Brothers	M.S.	Austfil 81N1M/mixed gas TM-71 HYD/CO <sub>2</sub> TM-811N1/CO <sub>2</sub> or mixed gas	FabCO 110K3M/mixed gas	FabCO 110K3M/mixed gas	N.R.
	L.S.	Austfil 71T-1/CO <sub>2</sub> Austfil 70C-6M, 71T-1M/mixed gas Formula XL-525/mixed gas FabCO 85/CO <sub>2</sub> or mixed gas Fabshield 4, XLR-8	TM-991K2/CO <sub>2</sub> or mixed gas Austfil 81N1M/mixed gas TM-71 HYD/CO <sub>2</sub> TM-811N1/CO <sub>2</sub> or mixed gas Metalloy 80N1/mixed gas	TM-991K2/CO <sub>2</sub> or mixed gas Austfil 81N1M/mixed gas TM-71 HYD/CO <sub>2</sub> TM-811N1/CO <sub>2</sub> or mixed gas Metalloy 80N1/mixed gas	Austfil 70C-6M, 71T-1M, 81N1M/ mixed gas Austfil 71T-1, TM-71 HYD/CO <sub>2</sub> TM-811N1/CO <sub>2</sub> or mixed gas Metalloy 80N1/mixed gas Formula XL-525/mixed gas FabCO 85/CO <sub>2</sub> or mixed gas Fabshield 4, XLR-8
	M.H.	N.R.	N.R.	N.R.	Vertiwear 600/mixed gas

Table 7 continued:

BRANDS		BISPLATE® 60	BISPLATE® 70	BISPLATE® 80	BISPLATE® 320, 400, 450, 500
Eutectic Castolin	M.S.	N.A.	N.A.	N.A.	N.A.
	L.S.	Teromatec OA2020	Teromatec OA2020	Teromatec OA2020	Teromatec OA2020
	M.H.	N.R.	N.R.	N.R.	N.R.
SWP/ Metrode ESAB	M.S.	N.A.	N.A.	N.A.	N.A.
	L.S.	Dualshield II 80-Ni1H4 Mixed Gas	Dualshield T-100 CO <sub>2</sub> Shielding Gas or Dualshield 7100 Ultra Mixed Gas	Dualshield T-115 CO <sub>2</sub> or Mixed Gas or Dualshield 7100 Ultra Mixed Gas	
	M.H.	N.R.	N.R.	N.R.	OK Tubrodur 15.40 (30-40HRC) CO <sub>2</sub> OK Tubrodur 15.52 (55-60 HRC) CO <sub>2</sub> or Self Shielded

M.S. – Matching Strength

L.S. – Lower Strength

M.H. – Matching Hardness

N.R. – Not Recommended

N.A. – Not Available

N.B. – Consumables in brackets will match mechanical property requirements in the majority of instances as per manufacturer's recommendations and where the appropriate weld procedure is applied. Weld Qualification procedures should be carried out to establish actual Weld metal properties.

\*Consumable recommendations overmatch mechanical property requirements.

## WELDING CONSUMABLES FOR SUBMERGED ARC WELDING (SAW)

Table 8:

BRANDS		BISPLATE® 60	BISPLATE® 70	BISPLATE® 80	BISPLATE® 320, 400, 450, 500
CIGWELD	M.S.	N.A.	Autocraft NiCrMo (Over)/ Satinarc 4	Autocraft NiCrMo (Over)/ Satinarc 4	N.R.
	L.S.	Autocraft SA1or SA2/ Satinarc 4 or 15	Autocraft SA1or SA2/ Satinarc 4 or 15	Autocraft SA1or SA2/ Satinarc 4 or 15	Autocraft SA1or SA2/ Satinarc 4 or 15
	M.H.	N.R.	N.R.	N.R.	Stoody 107/Stoody S Flux
Lincoln	M.S.	Lincolnweld LA-90/880M or 8500	Lincolnweld LAC-M2/880M*	Lincolnweld LAC-M2/880M	N.R.
	L.S.	L-60/L-61/761, 860, 960	L-60/L-61/761, 860, 960	L-60/L-61/761, 860, 960	L-60/L-61/761, 860, 960
	M.H.	N.R.	N.R.	N.R.	Lincore 30-S, Lincore 40-S Lincore 50 & 55/880
ESAB	M.S.	OK Tubrod 15.24S+OK 10.62	OK Tubrod 13.43+OK 10.62	OK Tubrod 15.27S+OK 10.62	N.A.
	L.S.	OK 12.22/OK 10.71	OK 12.22/OK 10.71	OK 12.22/OK 10.71	N.A.
	M.H.	N.A.	N.A.	N.A.	N.A.

M.S. – Matching Strength

L.S. – Lower Strength

M.H. – Matching Hardness

N.R. – Not Recommended

N.A. Not available

N.B. – Consumables in brackets will match mechanical property requirements in the majority of instances as per manufacturer's recommendations and where the appropriate weld procedure is applied. Weld Qualification procedures should be carried out to establish actual Weld metal properties.

\*Consumable recommendations overmatch mechanical property requirements.

At the time of printing all consumables listed were current/accurate but consult consumable manufacturer for up to date information.

## WELDING PROCEDURES

The specific effects of welding on weld joint properties in any practical situation will depend on many factors including the choice of consumables, total weld heat input, level of restraint, weld geometry and proximity of adjacent welds.

Guidance on weld procedures for specific applications may be sought from Bisalloy technical staff or consumable suppliers.

## ARC STRIKES

Arc strikes outside the welded zone can result in cracks, particularly on dynamically loaded structures. All strikes should be made within the joint preparation.

## TACK WELDING

Tack welds require special care due to the abnormal stresses and high cooling rates experienced by the adjacent material. The same preheat, heat input requirements should be employed and lower strength welding consumables considered.

## FILLET WELDING

Good fillet welding techniques are important in welding Q and T steels because often very high stresses are applied in service. It is essential that welds have good root penetration, be smooth, correctly contoured and well flared into the legs of the joined pieces. Lower strength consumables are suggested when design permits.

WTIA Tech. Note 15 provides guidance on correct procedures for fillet welding.

## REPAIR WORK

It is good practice to weld repair with lower strength consumables (low hydrogen type), since plate materials which have been highly stressed in service may tend to warp or distort slightly during welding and improved ductility may be required. In some situations, such as joints under restraint, joints subjected to impact/fatigue stresses, etc, special welding consumables may be necessary.

## WELDING STRESSES

It should be emphasised that the recommended values of preheat and heat input are based on low to moderate levels of restraint. For conditions of high restraint it is important to minimise the degree to which free contraction is hampered and it may be necessary to use higher preheats. Proper welding sequence and small joint configurations would be considered important in high restraint situations and it is advisable to establish welding parameters with simulated full scale weld tests.

Care should also be exercised at the assembly stage to avoid offset and angular distortion at the plate edge, undercutting and bad appearance.

## STRESS RELIEF

Stress relief may be conducted on BISPLATE® 60, 70, 80 and 80PV grades but is advisable only if absolutely necessary (eg. to comply with AS1210 in the case of road tankers). Stress relief is recommended within a 540 - 570°C temperature range for one hour per 25mm of thickness. Thermal cycling is generally performed in accordance with AS 1210 Code requirements for Q and T steels. The toes of weld beads should be dressed by grinding prior to any stress relief treatment in order to prevent stress relief cracking.

When stress relieving BISPLATE® ≤12mm (typically 0.40 CE(IIW)) and matching strength across the weld is a requirement, it is recommended to weld with minimum permissible preheat/ interpass temperatures (Table 2) and heat input (Table 3) conditions to minimise the degree of softening or any loss of strength which may occur in the HAZ.

Consult Bisalloy Steels® for further information if required.

## POST-WELD HEATING

Post-weld heating at 200-250°C may be conducted as an effective hydrogen dissolution treatment particularly when consumables other than H5 or H10 are used.

## HELPFUL HINTS

General rules for good quality welding of BISPLATE®:

- Use a low hydrogen process, eg GMAW (MIG), FCAW (gas shielded)
- Adhere to the correct rules for storage and handling of low hydrogen consumables per the manufacturers' recommendations, or WTIA Tech. Note 3
- Clean joint area of all contaminants prior to welding
- Remove 1 - 2mm from flame cut or gouged surfaces by grinding
- Select the recommended preheat, interpass and heat input parameters
- Position for downhand welding where possible
- Always use stringer beads, never wide weaves
- Use lower strength consumables on root runs and fillet welds (when the design permits)
- Use temper beads when necessary
- Arc strikes to be made in the joint preparation
- Particular attention should be given to tack welds re preheat, heat input and joint cleanliness requirements
- Grinding toes of fillet welds is particularly important in fatigue applications

## REFERENCES/FURTHER READING

- AS1554 Part 4 Welding of Q & T Steels
- AS1554 Part 5 Welding of Steel Structures Subject to High Levels of Fatigue Loading
- WTIA Technical Note 15
- WTIA Technical Note 3
- WTIA Technical Note 1

## BENDING, ROLLING, FORMING, SHEARING AND PUNCHING BISPLATE®

### FORMING

#### COLD FORMING

All of the BISPLATE® quenched and tempered steel grades can be cold formed, using brake press bending or plate rolling techniques.

However, with an increase in both hardness and yield stress compared to plain carbon steel grades, suitable consideration of sufficient machine power, plate bending direction and former radii must be made.

In addition, springback allowances should be greater than for plain carbon steel and will depend on the type of forming. Plate edges should be ground smooth, and for thick plates and high hardness grades, the plate edges should be rounded prior to forming.

It is recommended for the high hardness grades that where possible the bend axis be at right angles to the plate rolling direction (transverse bending). For plate 16mm and above in BISPLATE® 500 grade, it is suggested bending be done in the transverse direction only (refer to figure 1a).

Figure 1a:

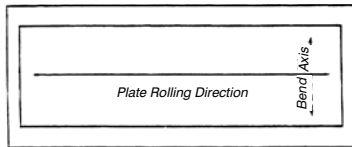

*Schematic of transverse bend direction.*

Figure 1b:

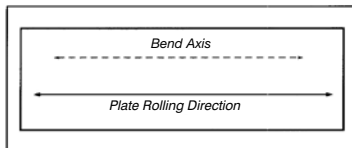

*Schematic of longitudinal bend direction.*

Figure 2:

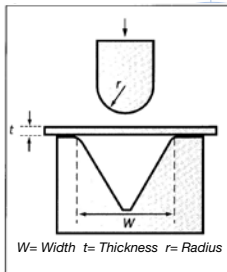

*Schematic diagram of brake press bending.*

## MINIMUM FORMER RADII (R) IN MM FOR COLD FORMING

Table 1 following gives the minimum former radii for cold forming of the BISPLATE® grades (where possible a larger former radii should be used).

Table 1:

BISPLATE® GRADE	60		70		80		320, 400		450		500	
Bend Direction	T	L	T	L	T	L	T	L	T	L	T	L
Plate Thickness (t) (mm)												
5	12	12	12	12	12	12	15	20	-	-	-	-
6	12	15	12	15	15	15	20	25	25	30	-	-
8	12	16	12	16	20	20	25	35	32	40	40	70
10	15	20	15	20	25	25	30	45	40	50	50	90
12	18	24	18	24	30	30	35	55	48	60	60	110
16	24	32	24	32	45	45	50	75	64	80	85	-
20	40	50	40	50	65	65	70	100	80	100	100	-
25	50	62	50	62	75	75	80	125	100	130	150	-
32	64	80	80	95	100	110	110	175	130	160	250	-
40	100	120	110	130	125	140	170	250	160	200	-	-
50	140	190	150	200	150	200	300	-	200	250	-	-

T: Transverse Bending Direction (refer to figure 1a).

L: Longitudinal Bending Direction (refer to figure 1b).

Notes re: Table 1

- Above values were determined for plate at a temperature of 30°C. If minimum former radii values are to be used, plate temperature should be at least 30°C, maximum 100°C. If forming at a temperature less than 30°C, an increase in former radii of minimum 50% must be made.
- When pressing is being done in a single pass operation, an increase in former radii of minimum 50% must be made.
- When forming using these minimum former radii, flame cut hardened edge (heat affected zone of 1-2mm) should be removed.
- The use of smaller former radii than in the table is not recommended.
- For best cold forming results, ensure adequate lubrication between the plate, die and former.
- Die openings: refer to Table 3.

## CAPACITY OF PRESS

All BISPLATE® grades have yield and tensile strengths higher than for plain carbon steel.

It is important that the capacity of the machine is suitable, bending press manufacturers provide information on bending loads in relation to V-block opening, plate thickness and steel strength.

Table 2 gives an indication of the approximate bending force required when forming BISPLATE® grades, compared to plain carbon steel (e.g. AS3678-Grade 250).

Approximate Bending Force (P) Required for BISPLATE® Grades, Compared to Plain Carbon Steel, for a Given Forming Geometry (refer figure 2).

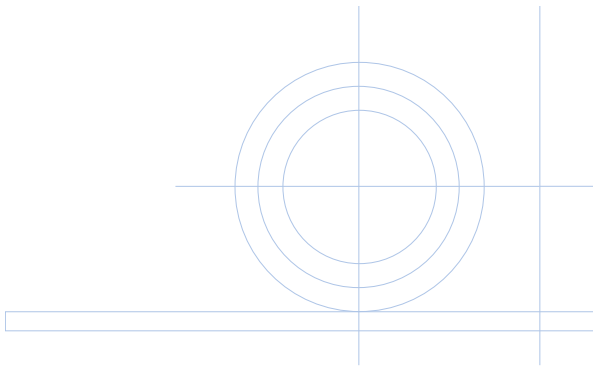

Table 2:

STEEL GRADE		BENDING FORCE (P)
AS3678 - Grade 250		P
BISPLATE®	60	2.0P
	70	2.4P
	80	2.8P
	320	4.0P
	400	5.0P
	450	5.2P
	500	6.4P

Approximate Die Openings  
(refer fig 2)

Table 3:

BISPLATE® GRADE	W/t TRANSVERSE BENDING	W/t LONGITUDINAL BENDING
60	6.0	7.5
70	6.0	7.5
80	7.0	8.5
320	8.5	10.0
400	8.5	10.0
450	10.0	12.0
500	10.0	12.0

## HOT FORMING

The operation of hot forming is not recommended for the BISPLATE® grades, as hot forming is generally done at a high temperature (900-1000°C) which exceeds the tempering temperature.

As a result, the mechanical properties of quenched and tempered steels will be reduced considerably.

However, if hot forming is unavoidable, it is essential that the component be requenched and tempered to restore original mechanical properties.

## SHEARING AND PUNCHING

Shearing and punching of the lower hardness BISPLATE® grades can be done successfully, provided a machine of sufficient power and stability is used.

BISPLATE® 60, 70 and 80 grades can normally be cold sheared up to 25mm thickness. However, the necessary shearing force is in the order of 2-3 times that required for plain carbon steel grades. The grades of BISPLATE® 400, 450 and 500 should not be considered for shearing.

The guillotine blades should be very sharp and set with a clearance of 0.25 to 0.40mm. Note, the maximum limiting thickness for cold punching are approximately half the cold shearing values.

## MAXIMUM THICKNESS FOR COLD SHEARING AND PUNCHING

Table 4:

BISPLATE® GRADE	COLD SHEARING	COLD PUNCHING
60	25mm	12mm
70	25mm	12mm
80	25mm	12mm
320	10mm	6mm
400	Not Recommended	Not Recommended
450	Not Recommended	Not Recommended
500	Not Recommended	Not Recommended

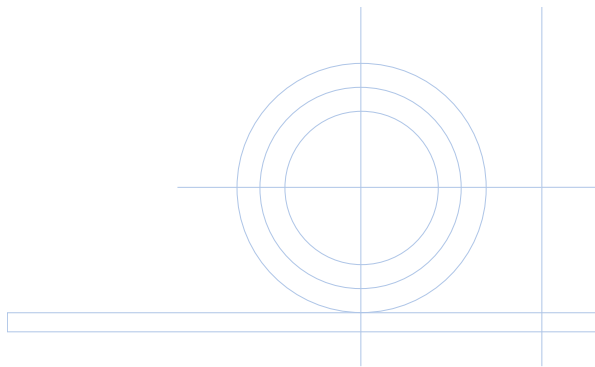

## DRILLING, COUNTERSINKING AND TAPPING BISPLATE®

### GENERAL INFORMATION

All grades of BISPLATE® are able to be drilled, countersunk and tapped although, as with most fabrication aspects, care should be taken with these grades of steel.

In all cases, suitable high powered and rigid drilling equipment should be used.

### DRILLING OF HIGH STRENGTH STRUCTURAL GRADES

When drilling the structural BISPLATE® grades 60, 70 and 80 the use of cobalt type high speed steel drills is recommended. Drills equipped with replaceable carbide inserts can also be used.

### DRILLING OF WEAR/ABRASION RESISTANT GRADES

BISPLATE® 320, 400 and 450 grades may be drilled with either cobalt type high speed steel drills or drills equipped with replaceable carbide inserts.

With regards to the drilling of BISPLATE® 500 grade, we recommend only the use of drills equipped with replaceable carbide inserts.

### RECOMMENDATIONS FOR IMPROVED RESULTS

- The supporting bars under the plate should be placed as close to the hole as possible
- If possible, use a plain carbon steel backing plate under the BISPLATE®
- The drilling head should be placed as close as possible to the main support
- Short length drills are preferred
- The last part of the hole to be drilled should be done with manual feed
- Usage of adequate coolant (water and oil emulsion mixture)

## APPROXIMATE FEEDS AND SPEEDS USING COBALT TYPE HIGH SPEED STEEL DRILLS

Table 1:

STEEL GRADE	PERIPHERAL SPEED (m/min)	R.P.M. (UPPER FIGURES) AND FEED PER REVOLUTION (mm) FOR GIVEN DRILL SIZE						HARDNESS (HB)
		5mm	10mm	15mm	20mm	25mm	30mm	
AS3678-Grade 250	~23	1465 0.10	735 0.15	490 0.20	370 0.25	295 0.35	245 0.4	~120
BISPLATE® 60	~20	1280 0.10	640 0.10	425 0.16	320 0.23	255 0.30	210 0.35	~220
BISPLATE® 70	~19	1210 0.10	610 0.10	410 0.16	300 0.23	240 0.30	200 0.35	~240
BISPLATE® 80	~18	1150 0.10	575 0.10	390 0.16	290 0.23	230 0.30	190 0.35	~260
BISPLATE® 320	~12	760 0.07	380 0.10	250 0.16	190 0.23	150 0.30	130 0.35	320 (min)
BISPLATE® 400	~9	570 0.05	285 0.10	190 0.16	150 0.23	110 0.30	90 0.35	370 (min)
BISPLATE® 450	~7	440 0.05	220 0.09	150 0.15	110 0.20	90 0.25	75 0.30	425 (min)

Note: This table applies when cobalt type high speed drills are used with a cutting fluid, if no fluid is used the speeds shown above must be reduced.

## Drill Tip Configuration for Cobalt Type High Speed Drills

Fig 2:

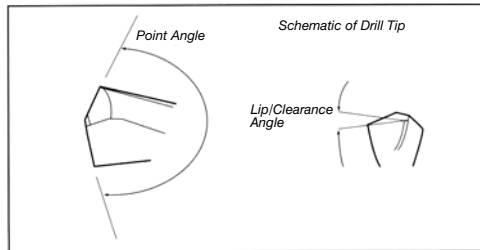

Approximate Feeds and Speeds Using Drills With Replaceable Carbide Inserts

### RECOMMENDED DRILL TIP CONFIGURATION FOR COBALT TYPE HIGH SPEED DRILLS

Table 2:

BISPLATE® GRADE	POINT ANGLE	LIP/CLEARANCE ANGLE
60	118 deg.	10 deg.
70	118 deg.	10 deg.
80	118 deg.	10 deg.
320	125 deg.	7.5 deg.
400, 450	150 deg.	5 deg.

## APPROXIMATE FEEDS AND SPEEDS USING DRILLS WITH REPLACABLE CARBIDE INSERTS

Table 3:

BISPLATE® GRADE	INSERT GRADE	SURFACE SPEED (m/min)	FEED RATE (mm/rev)	BRINELL HARDNESS
60	1020	125 - 210	0.06 - 0.18	~220
70	1020	125 - 210	0.06 - 0.18	~240
80	1020	125 - 210	0.06 - 0.18	~260
320	1020	125 - 210	0.06 - 0.18	320 - 360
400	H13A	125 - 210	0.06 - 0.18	370 - 430
450	H13A	70 - 90	0.06 - 0.14	425 - 475
500	H13A	70 - 90	0.06 - 0.12	500 (avg)

Note: Above drilling recommendations are based on using a Sandvik Coromant U drill and is based on hole sizes of 12.7 - 60mm diameter. Through the tool coolant must be used. It may be necessary to use different insert grades and geometries to suit the application.

Further information can be obtained from your local Sandvik Coromant office.

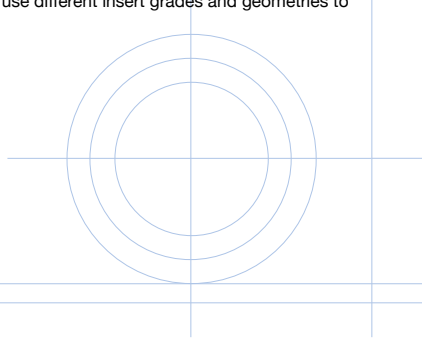

## COUNTERSINKING AND COUNTERBORING

Countersinking and counterboring of holes is possible in all BISPLATE® grades with best performance obtained using tools with a revolving pilot. The pilot increases the stability and allows tools with replaceable carbide inserts to be used.

Cobalt type high speed steel drills with a pilot can be used for the BISPLATE® grades 60, 70, 80, 320, 400 and 450. The cutting data will vary from machine to machine. A coolant should be used. Replaceable carbide insert tools should be used on BISPLATE® 500 grade.

## CUTTING SPEEDS AND FEEDS WHEN USING HIGH SPEED STEEL COBALT TYPE TOOLS

Table 4:

BISPLATE® GRADE	CUTTING SPEED (m/min)	Ø16		Ø20		Ø25		Ø32		Ø40		Ø60	
		RPM	FEED (mm/r)	RPM	FEED (mm/r)	RPM	FEED (mm/r)	RPM	FEED (mm/r)	RPM	FEED (mm/r)	RPM	FEED (mm/r)
60	10 - 12	250	0.05 - 0.2	200	0.05 - 0.2	160	0.07 - 0.3	110	0.07 - 0.3	90	0.07 - 0.3	70	0.07 - 0.3
70	9 - 11	210	0.05 - 0.2	170	0.05 - 0.2	130	0.07 - 0.3	90	0.07 - 0.3	60	0.07 - 0.3	60	0.07 - 0.3
80	7 - 9	170	0.05 - 0.2	130	0.05 - 0.2	100	0.07 - 0.3	70	0.07 - 0.3	60	0.07 - 0.3	40	0.07 - 0.3
320	6 - 8	150	0.05 - 0.2	120	0.05 - 0.2	90	0.07 - 0.3	60	0.07 - 0.3	50	0.07 - 0.3	40	0.07 - 0.3
400 450	4 - 6	130	0.05 - 0.2	105	0.05 - 0.2	75	0.07 - 0.3	50	0.07 - 0.3	40	0.07 - 0.3	30	0.07 - 0.3

## CUTTING SPEEDS AND FEEDS WHEN USING REPLACEABLE INSERT TOOLS

Table 5:

BISPLATE® GRADE	CUTTING SPEED (m/min)	Ø20		Ø25		Ø32		Ø40		Ø60	
		RPM	FEED (mm/r)	RPM	FEED (mm/r)	RPM	FEED (mm/r)	RPM	FEED (mm/r)	RPM	FEED (mm/r)
60	90 - 110	1675	0.15 - 0.20	1320	0.15 - 0.20	935	0.10 - 0.15	760	0.10 - 0.17	560	0.10 - 0.15
70	80 - 100	1500	0.15 - 0.20	1195	0.15 - 0.20	840	0.10 - 0.15	680	0.10 - 0.17	500	0.10 - 0.15
80	70 - 90	1340	0.15 - 0.20	1060	0.15 - 0.20	750	0.10 - 0.15	605	0.10 - 0.17	445	0.10 - 0.15
320	40 - 60	840	0.15 - 0.20	660	0.15 - 0.20	470	0.10 - 0.15	380	0.10 - 0.17	280	0.10 - 0.15
400	28 - 35	550	0.15 - 0.20	420	0.15 - 0.20	300	0.10 - 0.15	250	0.10 - 0.17	175	0.10 - 0.15
450	25 - 30	450	0.15 - 0.20	360	0.15 - 0.20	250	0.10 - 0.15	200	0.10 - 0.15	150	0.10 - 0.15
500	17 - 20	300	0.15 - 0.20	240	0.15 - 0.20	170	0.10 - 0.15	136	0.10 - 0.17	100	0.10 - 0.15

## TAPPING

With the correct tools and cutting speeds, tapping can be performed in all the BISPLATE® grades of steel. For the high hardness BISPLATE® 400, 450 and 500 grades, higher alloyed taps must be used.

Difficulties that commonly arise when thread cutting higher tensile strength steels include tap sticking, torn threads and the short life of taps. The Prototype brand tools have been specifically developed for tapping in the BISPLATE® grades of steel.

With all tapping it is recommended that the cutting speed is accurately controlled.

For best results, cutting oil or grease should be used. For through-holes of up to 2 times diameter in thread depth, in metric sizes, the following tapping tools are recommended.

Note: The introduction of stress concentrations (as a result of tapping) is an important consideration in fatigue applications.

## TAPPING SPEEDS AND TYPES RECOMMENDED FOR BISPLATE® GRADES

Table 6:

BISPLATE® GRADE	TAP TYPE (prototype)	TAPPING SPEED (m/min)	SIZE RANGE	LUBRICATION
60	Paradur 20360	15	M3 - M56	Cutting Oil
70	Paradur 20360	15	M3 - M56	Cutting Oil
80	Prototex Inox 202135	6 - 15*	M1.6 - M36	Cutting Oil
320	Prototex Inox 202135	6 - 15*	M1.6 - M36	Cutting Oil
400	Prototex Inox 202135	6 - 15*	M1.6 - M36	Cutting Oil
450	Prototex Ni 202602	3	M1.6 - M24	Cutting Oil
500	Paradur H/C 80311	1.6	M3 - M12**	Cutting Oil

\* 6m/min using steam tempered taps and 15m/min using tin coated tips.

\*\* For larger size threads, thread milling is recommended.

Bisalloy Steels® wish to thanks Sandvik Coromant and Ti-Tek for the information pertaining to drilling, tapping and countersinking contained in this publication.

## TURNING AND MILLING BISPLATE®

### MILLING AND TURNING RECOMMENDATIONS

#### MILLING

Milling operations can be performed satisfactorily on all BISPLATE® grades; utilisation of cemented carbide tooling is recommended.

In many situations, the milling operation entails the dressing of a flame cut edge, and then subsequent bulk milling of material to the desired surface finish and dimensional tolerance.

Care must be taken to make a first cut sufficiently deep to remove the heat affected zone of the flame cut edge. Cutters must be sufficiently robust to take this heavy loading. In such circumstances it is desirable that, due to the high hardness adjacent to the flame cut surfaces, cutter speeds and feed rates for initial milling should be reduced to 40-50% of the speed normally used when milling plain carbon steel. The importance of adequate preheating prior to flame cutting and slow cooling after cutting to minimise edge hardening is again emphasised. Speed and feed rates may be increased somewhat for subsequent bulk milling to 50-75% of the settings used for plain carbon steel.

#### MILLING RECOMMENDATIONS

Table 1:

BISPLATE® GRADE	CEMENTED CARBIDE TOOLING GRADE	SURFACE SPEED	FEED/TOOTH
60	GC4030	295m/min	0.25mm
70	GC4030	275m/min	0.25mm
80	GC4030	257m/min	0.25mm
320	GC4030	131m/min	0.25mm
400	GC4030	110m/min	0.25mm
450	GC4030	100m/min	0.25mm
500	GC4030	87m/min	0.25mm

Note: These recommendations are given as a guide only, and are based on stable working conditions. It is suggested a 45 deg. approach angle or a round insert facemill be used. In certain conditions it may be necessary to use negative geometry milling tools. Feed rates are dependant on geometry selected. Eg. PM medium machining (0.1 – 0.28) fz mm/tooth PH - heavy machining (0.1 – 0.42) fz mm/tooth.

## AVOID VIBRATIONS

Indexable inserts are sensitive to vibrations. These can be avoided or reduced by observing the following.

When turning or milling gas cut edges the cutting depth should be at least 2mm to cope with the hardness and unevenness of the edge.

Figure 1:

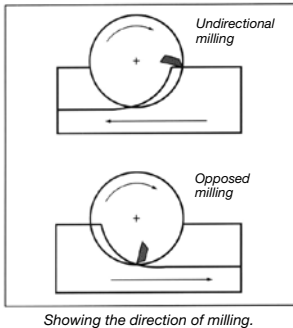
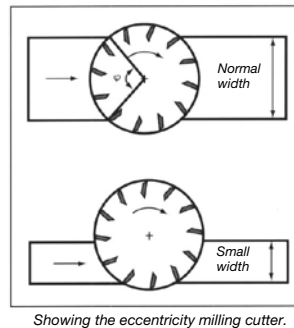

Figure 2:



## OTHER MILLING REQUIREMENTS

- Firm clamping of the workpiece
- Use cutters with the smallest possible gap between the teeth
- Machine stability permitting, unidirectional milling is preferable, see figure 1
- If a large cutter is used for the milling of small areas, place the milling cutter eccentrically to get as many teeth as possible operating, see figure 2
- Avoid, if possible, the use of a universal cutterhead which generally causes weakening of the power transmission and the tool holder

## TURNING

All BISPLATE® grades, including those with hardness in excess of 360HB can be turned satisfactorily with carbide tooling, provided spindle speeds and feed rates are reduced from those normally employed when carrying out similar machining operations on plain carbon steel. Reductions of 50-70% in spindle speed and up to 50% in feed rate may be necessary, depending on the hardness of the component being machined. High speed tools are not recommended.

As an example, the following settings have been found to give satisfactory results when turning cylindrical workpieces of 25mm diameter from the various BISPLATE® grades. With increases in stock diameter, spindle speeds will obviously need to be decreased.

### TURNING RECOMMENDATIONS

Table 2:

BISPLATE® GRADE	CEMENTED CARBIDE TOOLING GRADE	SURFACE SPEED
60	GC4025	295m/min
70	GC4025	275m/min
80	GC4025	257m/min
320	GC4025	131m/min
400	GC4025	110m/min
450	GC4025	100m/min
500	GC4025	87m/min

For operations under favourable conditions where higher productivity can be obtained GC4015 could be used.  
For operations with high toughness requirements and where increased security is needed GC4035 could be used.

Note: These recommendations are given as a guide only. And are based on stable working conditions. The geometry of the inserts used will be dependant on the operation.

Eg. PF for finishing. PM for medium machining. PR for roughing.

Figure 3:

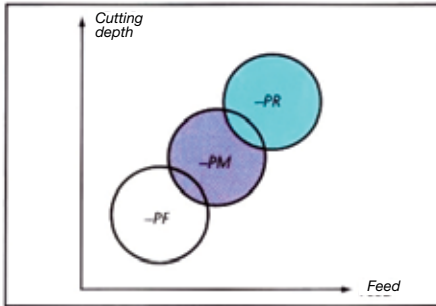

Geometry of Turning Insert: Finishing (F) Medium Machining (M) Roughing (R)

### OTHER TURNING REQUIREMENTS

- Firm clamping of the workpiece
- Avoid long overhangs for both workpiece and tool holder
- Use correct tip radius: too large a tip radius, combined with insufficient clamping, causes vibrations
- Small setting angles also can cause vibrations

Figure 4:

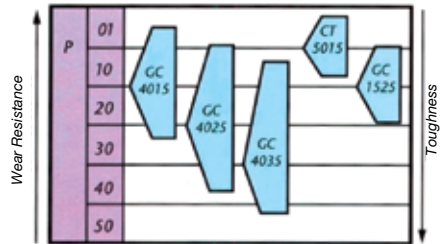

Diagram showing that some coated inserts combine toughness and hardness.

## FORMULA FOR THE CALCULATION OF SPEEDS AND FEEDS FOR GENERAL MILLING AND TURNING OPERATIONS.

Formula for calculation of cutting speed:

$$v = \frac{\pi \cdot D \cdot n}{1000} \quad \text{m/min}$$

Formula for calculation of turning speed:

$$n = \frac{v \cdot 1000}{\pi \cdot D} \quad \text{m/min}$$

Formula for calculation of table feed:

$$u = n \cdot Z \cdot Sz \quad \text{m/min}$$

$v$  = cutting speed m/min

$D$  = Diameter in mm of milling cutter or workpiece

$Z$  = Number of cutters

$Sz$  = Feed per cutter, mm

$n$  = Turning speed, rpm

$u$  = Table feed, mm/min

Bisalloy Steels® wish to thank Sandvik Coromant for information pertaining to milling and turning contained in this publication.

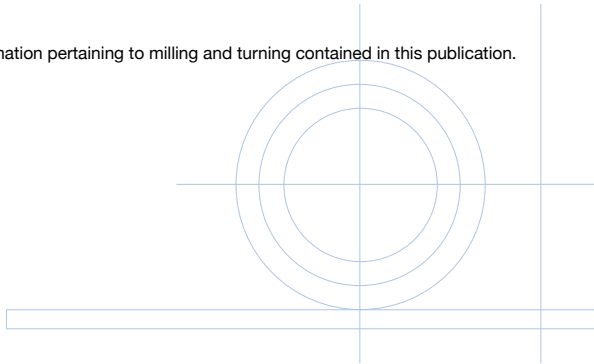

## BISPLATE® IDENTIFICATION MARKING AND COLOUR CODING

Bisalloy Steels® has a series of identification markings and colour codes to clearly identify the plate specifications and differentiate the grades from each other and other grades of steel. It is crucial that when plates are profiled that this identification is transferred to all off-cuts to prevent grade and size mixes.

**GRADE IDENTIFICATION STENCILS** - there are two grade id stencils on each plate located at opposite ends so that if plates are halved then each end remains identified. These stencils are colour matched to the grade colour coding.

**PLATE IDENTIFICATION STENCILS** – there are two plate id stencils on each plate located at opposite ends so that if plates are halved then each end remains identified.

For Domestic Orders

Customer Name  
Dimensions Plate Weight  
Grade  
Australian Standard (if applic.)

For Export Orders

Customer Name  
Customer O/No.  
Dimensions Plate Weight  
Grade  
Plate Number

Plates delivered via central stock will not have a customer name.

**PLATE CORNERS** – two diagonal corners of the plate are coloured with the relevant grade colour code.

One plate corner is hard stamped with the plate number.

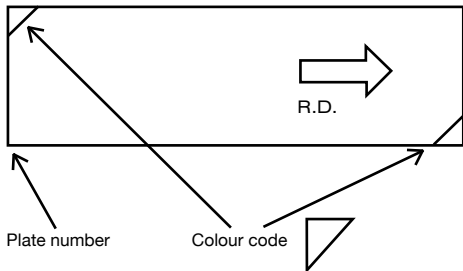

### GRADE COLOUR CODE

BISPLATE® 60	- White
BISPLATE® 70	- Lime Green
BISPLATE® 80	- Pink
BISPLATE® 80PV	- Pink/Red
BISPLATE® 320	- Light Blue
BISPLATE® 400	- Orange
BISPLATE® 450	- Yellow
BISPLATE® 500	- Black

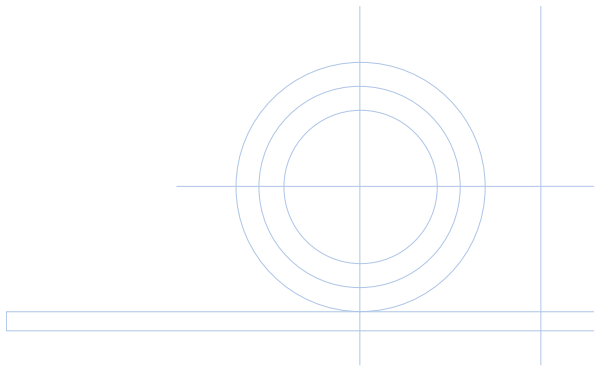

## TESTING AND CERTIFICATION

### MECHANICAL TESTING

**BRINELL HARDNESS TEST** – Brinell hardness test is performed in accordance with the requirements of AS 1816. All plates are individually hardness tested.

**TENSILE TESTS** – Structural steel grades only are tensile tested in accordance with the requirements of AS1391 and these tensile tests are done on a batch basis, per requirement of AS 3597.

**CHARPY V-NOTCH IMPACT TESTS** – Structural steel grades only are impact tested. Charpy V-Notch tests are done on a batch basis, per requirement of AS 3597.

Standard test direction is longitudinal and standard test temperature is -20 deg C.

Tests conducted in accordance with AS 1544.2 requirements.

## CERTIFICATION

A separate NATA certified test certificate will be issued for each full plate supplied. Tests are conducted in our NATA certified laboratory and will detail chemical analysis, hardness and relevant mechanical test information dependent on the grade ordered.

CHEMICAL ANALYSIS		LADLE ANALYSIS - PERCENTAGE OF ELEMENT BY MASS														
HEAT No.	BATCH No.	C	P	Mn	Si	S	Ne	Co	Mg	Cu	Al	Sn	Te	B		
721630		0.181	0.014	1.11	0.17	0.004	0.014	0.020	0.200	0.024	0.018	0.000	0.017	0.013		
		CA = .0002 N = 0.0003 Nb = 0.001 V = 0.002 C(ETW) = 0.38														
HEAT TREATMENT DETAILS		90FC/WQ / 610°C/1H														
MECHANICAL TESTS		TEST METHOD					AS 1381		AS 1816		AS 1844					
CUSTOMER SPEC.	FORM NO.	SERIAL NO.	PLATE SIZE (W x H x T) & WEIGHT & LENGTH			TENSILE STRENGTH MPa	YIELD STRENGTH MPa	ELONG. AT BREAK %	SCALES (mm)	PLATE THICKNESS (mm)	CHARPY V-NOTCH IMPACT TEST					
BRISTOL	347120	7068	1525 x 4.00 x 5.000			770	627	20	30	0.93	247	SPEC. SIZE FOR A 100    SW: 7500    TEMP: °C    ENERGY J    LATERAL DEFORMATION mm				
											 NORMAL STRONG ENERGY 100J NORMAL IMPACT VELOCITY 6.20 m/s					

**METADATA** (FORMER FACTORY FOR AS 1844)

100% = 20-40mm  
 750 = 5.000/7.000mm  
 75 = 1°C x 1.8) + 32  
 30 MPa = 4.30000 Psi

THE ABOVE CHEMICAL ANALYSES WERE REPRODUCED FROM FURNACE SUPPLIER WITH AN ACCURACY OF ±0.0001% UNLESS OTHERWISE SPECIFIED.

FURNACE SUPPLIER LABORATORY No. NATA No. 50122  
 FURNACE SUPPLIER CERTIFICATE No. 01755

WE CERTIFY THAT THE ABOVE INFORMATION IS IN ACCORDANCE WITH THE REQUIREMENTS OF THE COMPANY AND CONFORMS TO THE SPECIFICATION AS STATED.

**Samuel Barrett**  
 WITH SIGNATURE

## HARDNESS TESTING BISPLATE®

### WHAT IS HARDNESS?

Hardness is the resistance of material to plastic deformation – usually by indentation or penetration. It also defines the ability of material to resist scratching, abrasion or cutting.

### WHY TEST FOR IT?

Hardness testing is undertaken to:

1. Specify and certify a range of wear resistance products.
2. Double check the tensile strength of structural grade materials.
3. Assist in failure analyses and material identification.

Table 1:

METHOD	STANDARD	BASIS	MEASUREMENT	ACCURACY APPROX %	MAX TEMP
Brinell (4)	AS1816	10mm Tungsten Carbide ball (1) impressed under 3,000kg load	Surface area for known load	± 2	50°C
Vickers (HV)	AS1817	136° Diamond pyramid impressed under load	Surface area for known load	± 2	50°C
Rockwell (HR) A,B,C	AS1815 ISO6517-1	120° Conical Diamond Steel ball used for soft metals	Depth of impression under known load (15 - 150kg)	± 2	50°C
Equotip (2)	NIL	"Rebound" Method	Height of rebound	Poor	-
Poldi (3)	NIL	10mm Ball impressed with hammered test bar	Comparative impression	Very Poor (± 20)	50°C

## WHERE TO TEST?

Testing can be carried out in the laboratory, workshop or on site.

However, site testing with portable equipment can often have difficulties of access, surface preparation and vibration, which may reduce the accuracy of testing.

## TESTING PROCEDURES AND EQUIPMENT

The table above sets out the methods of identifying common indentation hardness, and other types of hardness tests. It is absolutely vital to understand the specific uses, strengths and any weaknesses of – and correct requirements and procedures demanded by – each of these methods in order to ensure consistent, comparable results in testing.

### INTERPRETING TABLE 1 – SOME IMPORTANT CONSIDERATIONS

1. Where the maximum hardness of the work exceed 450 HB, but doesn't exceed 650 HB, the standard says a tungsten carbide ball must be used.
2. Equotip is a "rebound" method of hardness testing, which does NOT measure hardness (indentation or plastic deformation) but gives a result convertible within a restricted range into an indentation hardness figure. This method is not standardised and gives only indicative results. It is extremely dependent on the operator, test material and surface condition. It is NOT recommended on quenched and tempered steel, or surfaces that aren't bright and smoothly ground.
3. The Poldi test is sometimes employed in the field. Even though it is an impression method, it displays very poor accuracy. It is not recommended for quenched and tempered steel.
4. The Brinell test is strongly recommended for all BISPLATE® grades as it is widely accepted as the industry standard. (Brinell gives a more definite reading, by leaving a more definite impression on the plate). It is the standard employed at Bisalloy and by other manufacturers, both on the production line and in the laboratory. The hardness rating on a certificate issued by Bisalloy is measured in Brinell hardness. Converted values from other methods such as Rockwell or Vickers (more often used in laboratory testing small samples of steel, or in small-parts engineering, and not ideal for use in the production environment) can cause small discrepancies from the Brinell rating on the certificate.

## PROPER PREPARATION OF THE TEST SURFACE

Since BISPLATE® is a quenched and tempered steel, some decarburisation will occur on the plate surface during the heat treatment process. The thickness of the decarburised layer (the very thin surface layer which has lost carbon during austenitising) will vary depending on the plate thickness. This decarburised layer will get thicker as the plate thickness increases.

To ensure testing accuracy, surface scale and the decarburised layer must always be removed by either grinding or machining from the areas where hardness measurements are taken. The minimum grinding or machining depths are listed in the Table 2.

Table 2:

PLATE THICKNESS	MIN GRINDING OR MACHINING DEPTHS (mm)
≤ 6	0.2
>6-10	0.3
>10-20	0.5
>20-50	0.7
>50-80	1.0
>80	1.5

Without removing the entire decarburised layer by grinding or machining, the results of the hardness test will be invalid.

It should also be noted that the area tested should be a min. of 75mm from any thermally cut surface to avoid any heat-affected zone.

The tested area must represent the whole material, must be clean, free from unwanted scale, and must be flat, sufficiently thick and smooth.

The test piece must be well supported and not subject to movement or vibration.

## CALIBRATION

To further ensure accuracy and consistency, all testing equipment must be calibrated (usually 3 yearly) and checked daily against calibration blocks.

## PERSONNEL COMPETENCY

For all tests, the operator requires training in the correct methods and assessment acceptable to the employer. Preference is given to NATA registered laboratories for high-risk applications.

## REPORTING

Reporting should include plate identification, location, method, result, date, surface condition, operator's name and signature. Refer to AS1816.

Table 3:

GRADE	SPECIFIED HARDNESS (HB)	TYPICAL HARDNESS (HB)
BIS80		255
BIS320	320 - 360	340
BIS400	370 - 430	400
BIS450	425 - 475	450
BIS500	477 - 534	500

Currently – already unique among other manufacturers – Bisalloy goes to the extent of physically testing every plate produced – that is, each one goes through the full process of grinding, test and measure.

The size of the indentation is measured using the latest video imaging technology, which is interfaced with a dedicated computer to generate a BH number to within one point.

This testing procedure is now fully automated including automated grinding and indentation, guaranteeing an even greater and more consistent level of accuracy and repeatability.

### Disclaimer

*Every care has been taken to ensure the accuracy of information contained in this manual which supersedes earlier publications, however Bisalloy Steels® shall not be liable for any loss or damage howsoever caused or arising from the application of such information. Typical values are provided for reference information only and no guarantee is given that a specific plate will provide these properties. Specification correct at time of printing, however information is subject to change without notice.*

### Registered Trade Marks

 **Bisalloy Steels®** Bisalloy Steels® Bisalloy® BIS® BISPLATE® are all registered trade marks of Bisalloy Steels Australia Pty Ltd.

Print Date: August 2011



For more information regarding BISPLATE<sup>®</sup> refer to the technical information pdf documents provided on the Bisalloy Steels<sup>®</sup> website at [www.bisalloy.com.au](http://www.bisalloy.com.au)



**Bisalloy Steels Pty Ltd**

18 Resolution Drive, Unanderra  
PO Box 1246, Unanderra  
NSW, Australia, 2526

Ph: +61 2 4272 0444

Fax: +61 2 4272 0456

Email: [bismail@bisalloy.com.au](mailto:bismail@bisalloy.com.au)

Web: [www.bisalloy.com.au](http://www.bisalloy.com.au)